

## HOW I REBUILT MY BLOWN KENWOOD TS-930S

(With an Addendum on how to convert the later dual-voltage AVR board rigs to a modern power supply)

John Young, W3AFC

**DISCLAIMER.** This paper describes how I rebuilt my Kenwood TS-930S transceiver using an industrial rail-mount switching power supply. While this has been done by others and it works very well, I recommend reading this paper in its entirety before gutting out your existing power supply, if it works. While I am very happy with my results I can't be held liable if you perform this conversion and are not satisfied. The mods described herein do not require advanced knowledge or skills. All you need is a fine-tip soldering iron and a Digital Multimeter (DMM).

**Background.** The Kenwood TS-930S is a true HAM OP's radio, with a logical control layout and features that make it competitive in contests even against today's radios. When it's working, it's true love. When something goes wrong with mine, I want to toss it out a window. I *would* say "torch it", but I've already done *that* by accident. My rig is a first-year production run with a serial number of 3,060,xxx, but this conversion is easy with the later models also (see Appendix). This model seems to suffer from a number of reliability issues as it ages, but the only two areas that I've experienced trouble with so far are the power supply, and the Power Amplifier (PA).

**The Problem:** I was in the middle of a QSO with a station in Latvia when suddenly the other OP started asking "W3AFC? Are you still there?" Everything seemed normal and even the "On the Air" light was still working. But it wasn't putting out a signal and now Ic and Power were at "zero". However, Vc was right on 28 volts. I shut down and dug in to find the problem. It sounded like a relay wasn't engaging, which led me to RL-3 at the rear underside of the signal board.

**Diagnostics:** My tests with an RF probe showed a little over 3-V P-P of RF at RL-3, and a quick check with my 830"Sugar" revealed that a nice clean modulated signal was present at the indicated frequency. But when the 930S transmit was engaged, RL-3 didn't close, so that RF went to the transverter socket on the back. It appeared that a protection circuit was keeping RF from reaching the PA by disabling RL-3. Believing that the relay itself or the coil circuit had failed, I fed the RF through a jumper to the PA but nothing happened. I would soon learn that the circuit is part of transceiver control line TXC, which comes from a 3-pin plug on the PA board near the power leads. The center is 18 volts in, and it feeds that voltage through thermistor TH1 back to the Low Pass Filter (LPF) via the TH line. The TXC line connects to the base of Q9 on the PA, and is part of a transceiver control circuit that is centered on IC1. All of this is becomes obvious if one has a clean copy of the schematic for the PA, which I found in a high-quality User's Manual PDF on Kenwood's web site. Once I had that, I began to suspect the PA, so I turned my attention there.

Then, while measuring voltages in the PA, I accidentally touched the 28V B+ at Q7's collector to ground. I was using a probe with an insulated cover, but somehow it still made contact. The rig's lights dimmed for a second and there was a click like a protection circuit had kicked in, and then everything came back to normal, like nothing had happened. A dummy load was connected and I could hear a strong local QSO coming from the speaker. But before I could give a sigh of relief, two carbon resistors on the AVR board burst into flames and set half the board on fire. I now had TWO problems to deal with.



**The Power Supply.** My first impulse was to look on eBay for a replacement AVR board, and I actually found the exact one for under \$100 with shipping. But the OEM power supply was always a major area of concern for me and I began to question the wisdom of sinking money into it. I was so concerned about heat-related issues that I bought a pair of 6-inch home theater amplifier cooling fans that came on the moment I switched on the rig. Heat poured out through those fans.

Volumes have already been written about improving the original voltage regulator-based power supply, including white papers by PhD's in Electrical Engineering, so I won't try to expand on that subject. For those who are unfamiliar with the problem, here's what happens: One of the TO-3 regulator transistors opens, and the AVR board feeds 40.5 volts DC instead of 28V to the PA unit. The MRF485 driver transistors are rated at a maximum of 35-volts Emitter-to-collector, so they blow. There goes \$50.00 or more in a flash. The 19-volt Zener diode, D5, usually shorts too. There's no point in rebuilding a 30-year old linear power supply like this one when there are modern solutions to this problem that are safer, lighter, and that operate at MUCH lower temperatures. I investigated three different power supplies:

- A 28-volt, 300-watt Nao Technologies open-frame switching power supply,
- An Acopian 28-volt, 14 amp continuous (392 Watts) "Gold Box" W28MT14 power supply, and
- Two Phoenix Contact Quint models with outputs that are adjustable from 24 to 28.5-volts or more.

The two Phoenix Contact supplies are rated at 10 amps continuous at 24 Volts, but they have a "boost mode" reserve that lets them run up to 15 amps<sup>1</sup>. This allows them to produce 360 watts max at 24 volts, which translates to about 12.6 amps at 28.5 volts. I liked the Acopian's continuous rating of 14 amperes at 28 volts and 392 watts, but based on its published dimensions I could not make it fit without relocating the PA. In addition, the Acopian has an AC input range of only 90-132 VAC versus 85-264 VAC for the Quint. Since others have installed the Quint with success, I decided to try it.

The maximum stated power dissipation of the 930S during transmit is 510 watts, but that figure includes transformer and other losses due to the low efficiency of the original power supply. In reality, the 930S needs about 350 watts, based on the specifications. The PA input power is 250 watts. The receiver by itself uses 80 watts, and although the receiver is muted during transmit, it's still drawing power. So now we're up to 330 watts. If your rig has the built-in antenna tuner, it will draw power also (the exact figure is not stated in the User manual). And then there are the fans to consider. So the Phoenix Quint 10-amp model at 360 watts boost is *JUST* adequate. Fortunately, the Quint's data sheet states that at ambient temperatures of up to +40°C (104° F) the boost mode reserve is available *continuously*. At higher temperatures it is available for "around" ten minutes. But the PS would not have to provide boost power that long, even in FSK mode. The Owner's manual warns that output power should be reduced by 50% to prevent damage under those conditions.

A quick eBay search turned up a couple NOS surplus units for about \$70 with shipping. The model I chose is the 2866763, shown below. This version has three sets of output terminals, all in parallel, which makes it easier to hook the existing wires in. But I only ended up using two of them, so the other Quint model which has two sets of outputs would work just as well. That model number is 2938604. According to the published literature, the 2938604 model is 25 mm "thicker" than the newer 763 version. Both come with a rail mount on one side, which is easy to remove.



1. Phoenix Contact now makes a 20/26-amp model that will fit in the 930S (see Appendix)

**IMPORTANT:** Some people recommend gutting out everything associated with the old power supply system, including the power relay near the voltage selector switch. That relay feeds 120 or 240 volts up to separate windings on the power transformer. I removed all of that, but then I realized that Kenwood ran very fine wires up to the front panel power switch, since they only need to carry the low current of that relay coil. But now those wires would have to handle enough primary side amps to provide 360 watts output. I felt the need to run heavier wires up to the switch. I'm concerned now that the increased load on the main power switch will result in poorer reliability than that relay system. I recommend leaving in the relay system and just using the solid-conductor wires to the transformer primaries that are already in place.

You will need to remove the transformer and bracket, filter capacitor assembly, voltage regulators and heatsink, and the AVR board. I used the AVR board to run the fans and front panel meter as you will see later. These can all be lifted out as one big mess with the wires still connecting them together. Set these parts aside for now.

The photo below shows my model 763 Quint mounted in my radio. It fits right where the transformer was, with just enough room for the AVR board. At this point, I wanted to reconnect the receiver while I dug into the PA section. I was accustomed to using my 930S with my Swan 700's when the noise floor at my QTH overloaded the older Swan receivers. I've experienced a dramatic increase in impulse noise at my shack, so I often use my 930S as a receiver. But I also wanted to see if switch-mode power supply noise would cause interference in the 930s. If it did, I could stop right here before I invested more time and money in this solution.

### The Phoenix Contact Quint mounted in my TS-930S

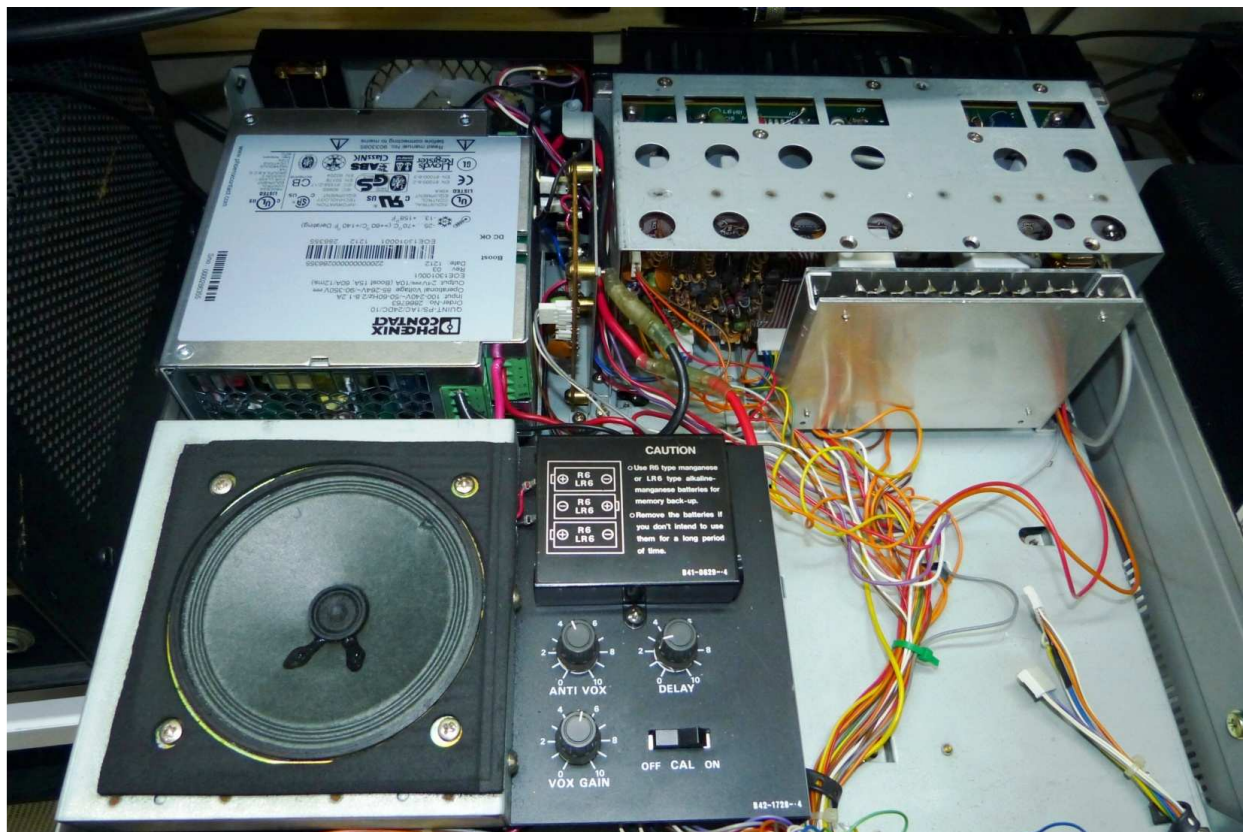

I took the easy way out by simply connecting the 28-volt B+ output lines from the AVR board to the terminals on the Quint. The original voltage divider system for the sub-voltages worked fine, so after testing it I decided to leave that alone. I connected the heavy black chassis ground lead to the ground terminal on the AC in side of the Quint, which required adding 4-6 inches of #10 stranded wire. I did it that way because with just the receiver in the circuit I noticed a 0.25 volt difference in DC potential between the negative terminals on the DC side of the Quint and chassis ground. I suspected that the DC minus line inside the Quint was designed to “float” rather than operate at chassis ground. Once the grounded black lead from the PA is connected to a negative terminal on the Quint, those terminals will be forced to chassis ground anyway, so connecting the heavy black lead to the Quint’s minus output side would probably not cause a problem. But I decided not to risk it, since everything was working perfectly the way I had it hooked up.

**IMPORTANT NOTE: Literature from Phoenix states that their power supply has an internal low-pass filter, designed to shunt switching noise to ground. THAT is probably where the 0.25 volts comes from. For what it's worth , I have no switching noise in my receiver, so I would let the DC ground "float".**

Here's a closer look at how I mounted my Quint. I used the transformer mounting bracket, but I turned it 90 degrees so that when I mounted the PS, the air intake and outlet would be in line with the original VR heat sink fan. The older 2938604 model is almost an inch taller than the one I used so you can't use the transformer bracket as a mount. If you do the power supply will be too high for the top half of the case to fit once you're finished.

I used 3M snap lock fasteners to hold the Quint in the bracket so that I can remove it if I have to. If I plan to travel with the rig I'll put a pair of 18-inch plastic zip ties around the ends of the power supply and the bracket to lock it in place. But the snap fastener system is so strong that any impact that would shake the Quint loose would surely cause damage to other parts of the rig as well. You may have to shorten the top cover screw next to the Quint in case it hits.

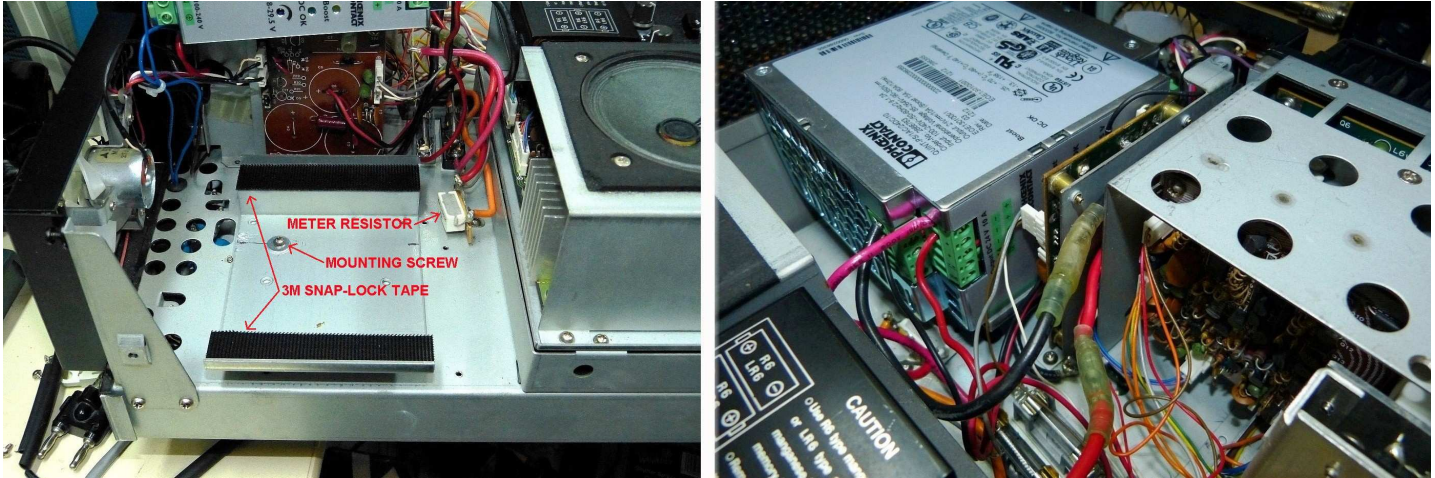

The resistor that creates the voltage drop for the panel meter is mounted to an existing hole for the old filter capacitor housing. I didn't want to drill new holes in the chassis because I was afraid shavings might go somewhere they shouldn't and give me another problem to fix when I switched on the rig. It looks close but there's a half inch of clearance. I drilled new holes in the transformer bracket instead of the chassis for the mounting screws the same reason. The fuse holders are held securely by high strength 3M double-sided foam tape. You could use three or four 1-inch wide strips of that tape to mount the bracket to the chassis instead of drilling and it would never work loose. With everything in place, the rig looks stock from the rear, except you can see the interior of the Quint power supply, and there's no screw in the case above the fan. I put in that case screw back in with a nut to make it look stock.



Some HAMs who have performed this modification have removed the parts they need from the AVR board and mounted them on a terminal strip, but I gutted the board, leaving on the connectors for the fans, as well as the two small green inductors for  $I_c$  and  $V_c$  at the front panel meter.<sup>2</sup> Also, I needed a place to mount a 250-ohm dropping resistor to run the cooling fans at reduced speed when the rig is turned on (red). I had to use wire jumpers to the fan connectors because the foil traces were burned completely off the board. With respect to that resistor, I used a 5-watt wire wound. The PA fan measured 59 ohms cold resistance, and the PS fan 47 ohms. So with the fans wired in series, the total resistance is 356 ohms. With 28 volts, the calculated current is 78.65 milliamps, which amounts to 2.2 watts dissipation. Once the fans are running, the impedance of the fans will be higher so the dissipation will be even lower. So a 5 watt resistor works fine. This results in a solid airflow without any discernible noise. If you want more flow, you can wire the fans in parallel, which results in 276 ohms, and brings the wattage up to 2.84 watts. In a quiet room, you'll hear the fans, but it's still not intrusive. But with the switching power supply, heat will no longer be an enemy, so I used series for my own rig.

**NOTE:** I also reworked a newer split-voltage board so that owners of "post 3,100,xxx" model 930's can use a switching power supply – See the Appendix at the end of this paper.

### My AVR board, ready to reinstall!

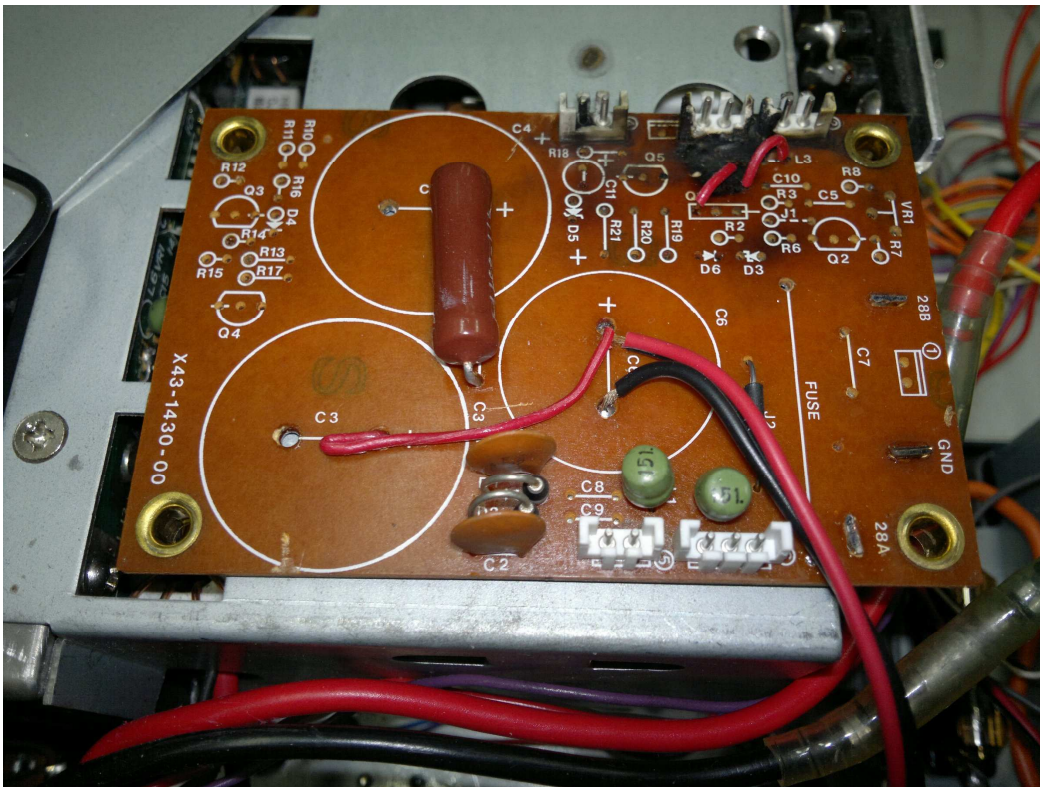

I put the receiver and digital board circuits on a separate fuse from the PA. The receiver consumes 80 watts at 28.5 volts, which translates to 2.8 amps. A 3-amp slow-blow fuse works perfectly. For the PA, I used a 10-amp slow-blow. I hooked the rig up to a receive antenna and everything was loud and clear, without a trace of harmonics or switching hash. These are industrial-grade power supplies that retail for over \$500, so I would expect them to have noise filtration built-in.

2. The two diodes and the disc capacitors actually aren't used here. I left them on the board in case I needed them to achieve proper operation of the front panel meter. But the panel meter works just as it did with the old power supply.

**The Power Amp:** With the receiver back online, it was time to dig into the PA. Nothing appeared burned nor were there any odors. But a run-through with a DMM/diode tester revealed that driver transistor Q2 was shorted, and Q3 was open. The 19-volt Zener diode D5 was also shorted. But the expensive Motorola NRF 422 outputs tested good. WHEW!

I ordered replacement MRF485's from an Eleflow dealer in England. They were \$15 each, and shipping was another \$15, so I paid \$45 for the two. There are cheaper brands out there, but I've heard they have too much gain which may cause oscillations that destroy the finals. The Eleflows arrived quickly. For D5, I bought a 5-watt version (NTE 3154A) for under \$3.00 from Radio Shack to replace the original 1-watter.

Installation of the replacement parts was pretty straightforward. The main thing to remember is that the drivers must sit parallel to the bottom of the circuit board, with the top of each transistor flush with the bottom of the PC board. Otherwise, the tabs on the drivers won't lie flat on the heat sink assembly and you may end up frying your new drivers. Look at your old drivers to see how the leads were bent. You don't want to have to bend them more than once or twice, because if one breaks off from fatigue at the body, you're hosed. Remember also not to go overboard when soldering in the drivers. The leads will be very short and the heat will go right to the transistor junctions.

Once everything is in place, it's time for some resistance and diode tests before you power up the PA. I used the schematic from Kenwood as a guide. It comes in two sections so I used PhotoStudio to stitch it together as one. A large version is in the APPENDIX section at the end of this paper.

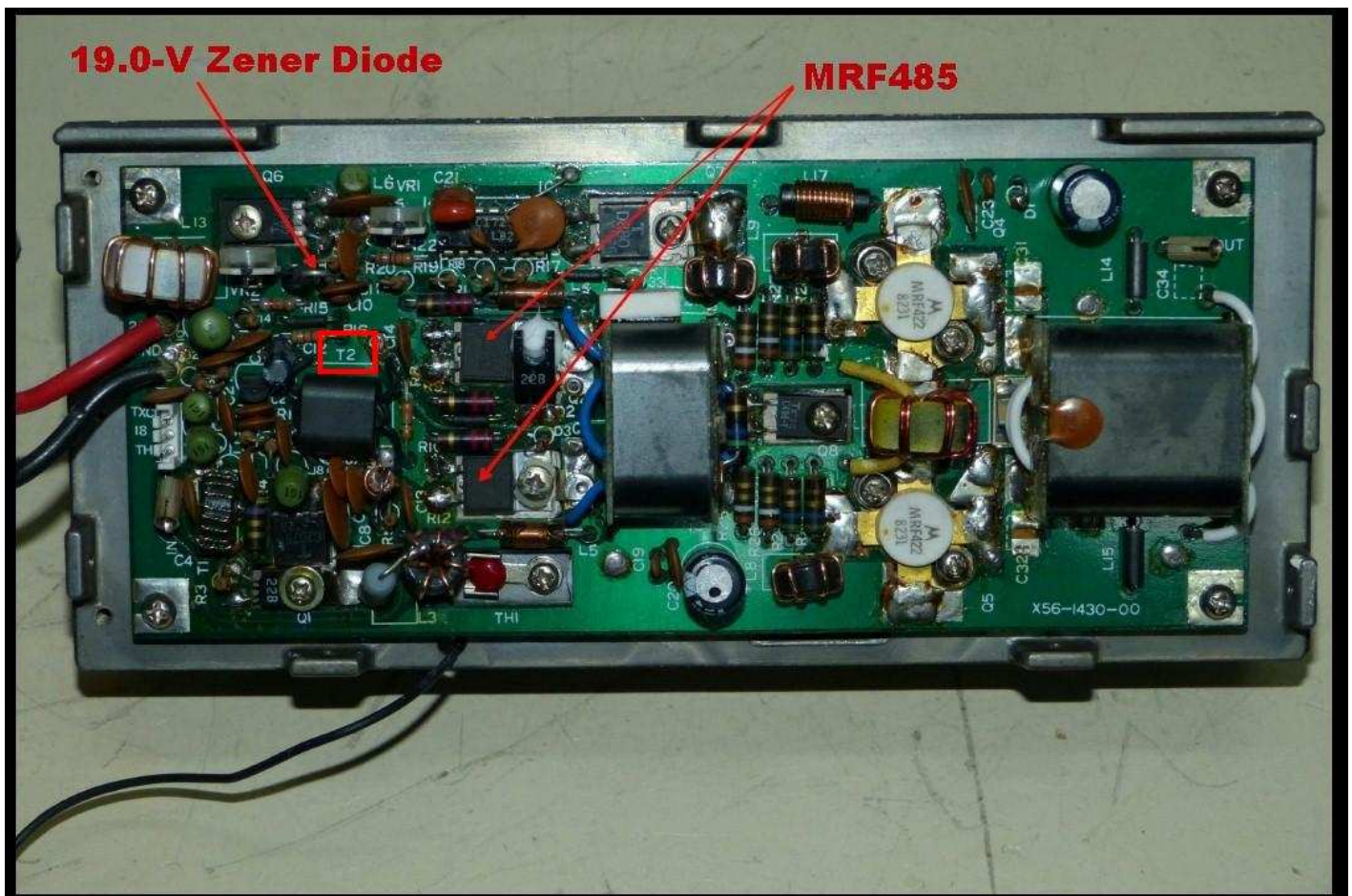

Apparently, my rig had been worked on at least once before because someone had already fed thin wires through some of the thru holes, including the emitter and base ferrules at Q2 and Q3. A couple foil traces had been bypassed with wires also. In addition, some of the wire bundles under the signal board were held together with white kitchen ties. I'm pretty sure Kenwood didn't put those there.

The first thing I noticed after installing everything was that an almost dead short appeared across D5, and worse yet, it appeared across the Emitter-Base leads on both drivers as well. Mine measured 15.3 ohms. However, if you look at the schematic below, you will see why. Q6's emitter, along with D5, C10, C11, and C12 are connected to the center-tap on the secondary of transformer T2. And the ends of T2's secondary are connected to the bases of Q2 and Q3. Since the emitters are grounded, and T2's secondary is grounded on one end through a 22-ohm resistor, the circuit appears to be shorted - but it's not.

I checked with a DMM to make sure all of the emitters that are supposed to be grounded were, and those that aren't weren't. I checked and rechecked diodes and other components as well as the shoulder washers on the collector tabs of the drivers and other transistors. I also tested for a diode relationship across the main power input leads to the PA. Finally, I bolted it all back together, hooked up the wiring, connected a dummy load, and turned the rig on.

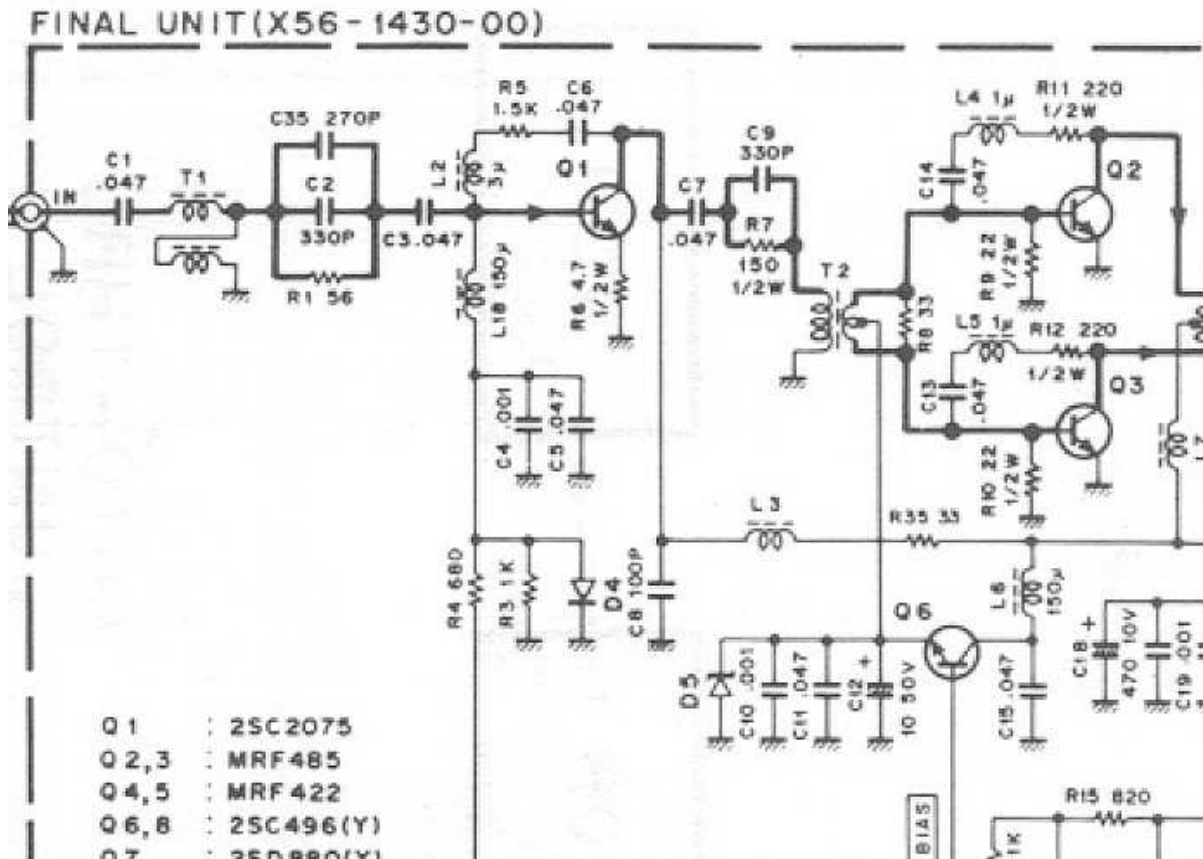

**NO SMOKE!** That was good. Before powering the rig up I connected my MC-50 microphone, turned off the processor, and turned the mike gain all the way down. I eased the gain up a notch or two and blew gently into the mike, and the power needle on the rig and on my peak reading wattmeter swept up to about 20 watts. I gradually increased the mike gain until the rig was putting out over 100 watts. Time to switch in the antenna!

I heard W1AW/7 calling from Oregon, and I called back. They came back to me immediately and gave a 59 report. I told them this was the maiden voyage of my now rebuilt 930S, and they said it sounded great. After a few more contacts, I dove into the SP DX contest that was underway, and everyone said the audio was perfect – classic Kenwood.

This is my baby, back in the lineup. It works just like before, except now I can put it on the upper level of my shack hutch because it weighs only 28 lbs. The overall weight loss was around 10 lbs. And the rig is balanced and easy to carry. It was “left-heavy” before due to the location of the power transformer. It runs so much cooler that I could set magazines on top, but you can bet I won’t. Now that it’s up and cruising again, I’ve adjusted the output voltage on the Quint up to 28.5 volts. I started it at 26.5 VDC because I was worried about another blow up.



After operating it for a few days, I had to see how often the Quint power supply was entering boost mode when operating at full power, so I pulled the cover and watched while I talked. Although the data sheet from Phoenix Contact states that the Quint can operate in boost mode almost continuously, I wanted to see if it actually was. I was most interested in SSB, but I also tried AM and CW modes. This is what I discovered:

On strong SSB voice peaks where the PEP reached 100W or more, the yellow boost light came on! (See photo below) On CW it came on full brightness every time I keyed down. But it stayed dark on AM, probably because AM output is limited to 40W. This proves that the Nao Tech 28-volt, 10.7 amp power supply that I was considering in the beginning would not have had enough power to run this radio. But the Acopian 14-amp supply should have worked perfectly, had it fit.



## The Yellow BOOST Mode Light on the Quint Power Supply

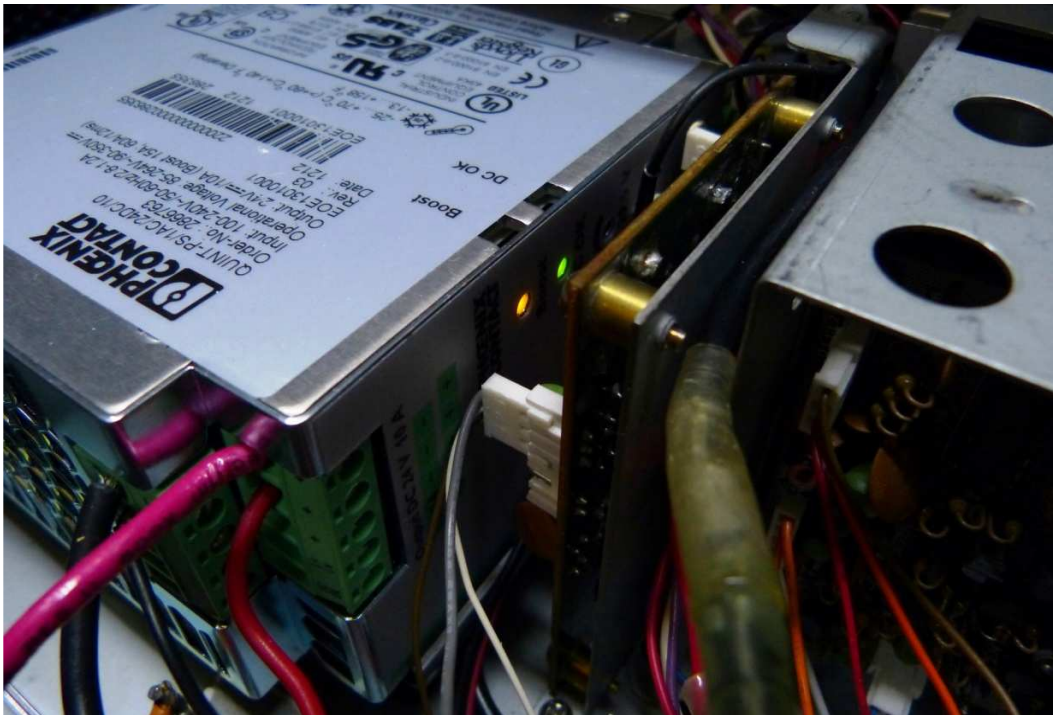

### **One month later: How does it compare?**

After a month of almost nightly use with the switching power supply, I have to say I'm very happy with the mod. The Quint handles the load easily, and after a full day of contesting or other use, the top of the rig is barely warm. The only part that generates any heat is the resistor bank assembly in front of the Low Pass Filter assembly. I even left my 930S on overnight by accident, and it didn't get warm.

**UPDATE:** Phoenix Contact has a newer model PS that is rated at 20/26 amps, and based on the published dimensions, it will fit in the 930S. It's model number 2866776. The published dimensions are 130mm long x 125mm wide x 90mm (3.54 in.) high. While this is substantially taller than the 2866763 model that I used, it's only 5mm higher than the popular 2938604 that other HAMS have used. That means it will fit in the 930S. At 624 watts, this Quint is stronger than the OEM power supply, so if you push the rig into a high SWR, it won't back down. That might spell disaster for your drivers.

## APPENDIX

I decided to add this section so that I could include additional photos, schematics, and also instructions on how to modify your “post 3,100,xxx” serial number AVR board to work with the Phoenix Contact or other switching power supply.

### **Rebuilding a TS-930S with the 28.5 & 21.7-volt AVR Board**

If you have a later model 930S with the dual-output AVR board and you don't feel like re-building the AVR board (or yours is completely fried), eBay sellers offer solutions - small adjustable converter boards that typically reduce 3-40-volts down to 1.5-35 volts. There are even some that appear to be scaled-down versions of the Phoenix Quint. Many can handle 4-5 amps without a heat sink. I have to confess, I bought one just to play with. Most cost less than \$15.

Phoenix Contact also sells a Quint-Series DC-DC converter that has the same 125mm x 130mm length and width as either of the Quint power supplies discussed above. Its depth is 32mm, so if you mount a “big Quint” directly to the 930S chassis using the 3M snap-lock fastener system, the smaller Quint could sit on top using 3M double-sided tape and you could even line the terminals up so that the two could be removed as a package for service (no, I don't work for 3M) . The Phoenix Quint converter handles 5 amps. The part number for it is 2320034. It lists for \$267, but no doubt you could find it on eBay for a lot less.

Or, you can do what I did and strip the original AVR board down to the bare essentials, and reuse it. The board that I rebuilt for another HAM (N6BIZ) suffered the same blowup and fire that mine did, but the components that generate the 21.7 volts survived unscathed.

### **A fried “Post 3,100,XXX” AVR Board. The same two carbon resistors exploded!**

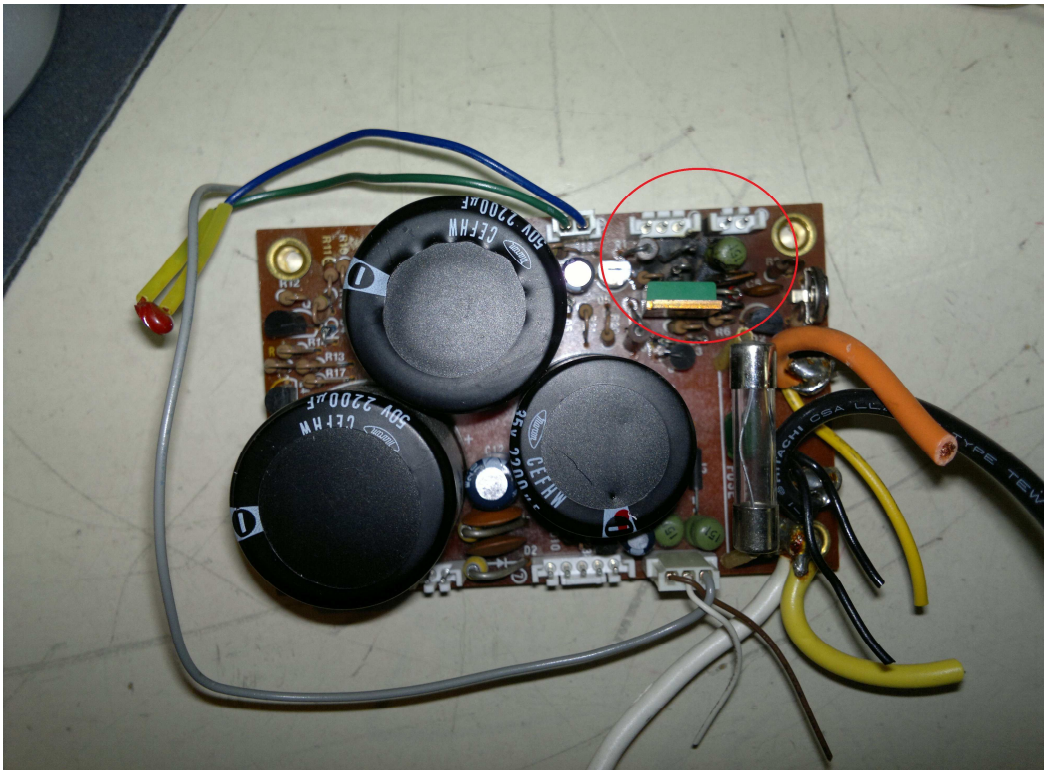

The strip-down procedure for this board is pretty much the same as with the older AVR's. You just need to leave on Q6 and its associated components, and keep the TO-220 regulator Q3. If you toss the OEM PS heat sink, you will need to mount Q3 to the chassis or some other heat sink, or else it may end up in “electronics component heaven”.

**The Dual-Voltage AVR Board schematic with the pertinent circuits highlighted**

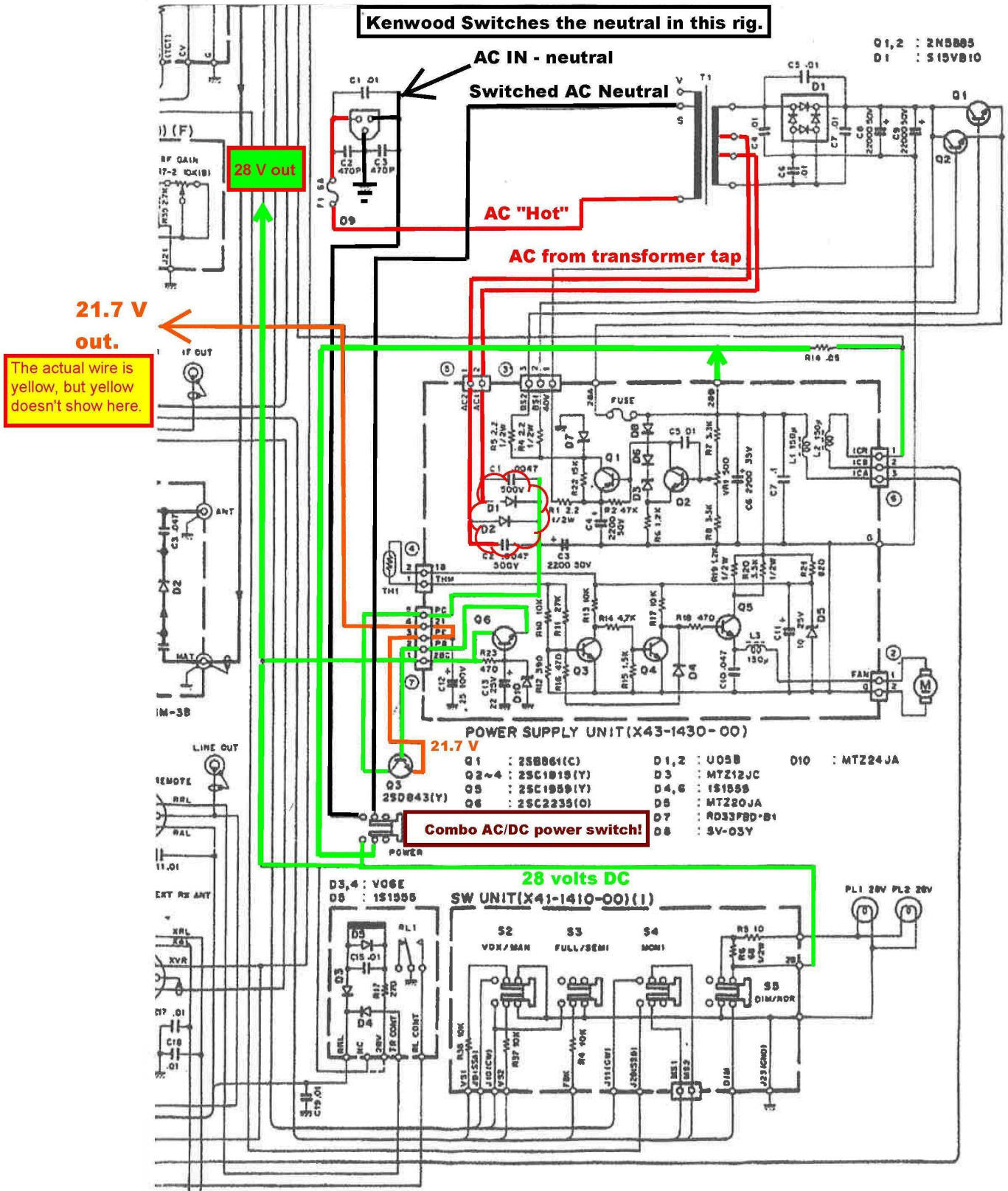

THIS is what your board will look like after it's stripped. Note from the schematic above that the 21.7-volt sub-system is literally stand-alone. It's fed 28-volts DC through the power switch from terminal 28B into pin 1 of the connector, while pin 5 receives 28 volts DC from a separate circuit via diodes D1 and D2. I used jumpers to the 28-volt line from the Quint, and everything works fine. Be sure to leave on the ferrite bead jumper and the green inductors for the panel meter circuit.

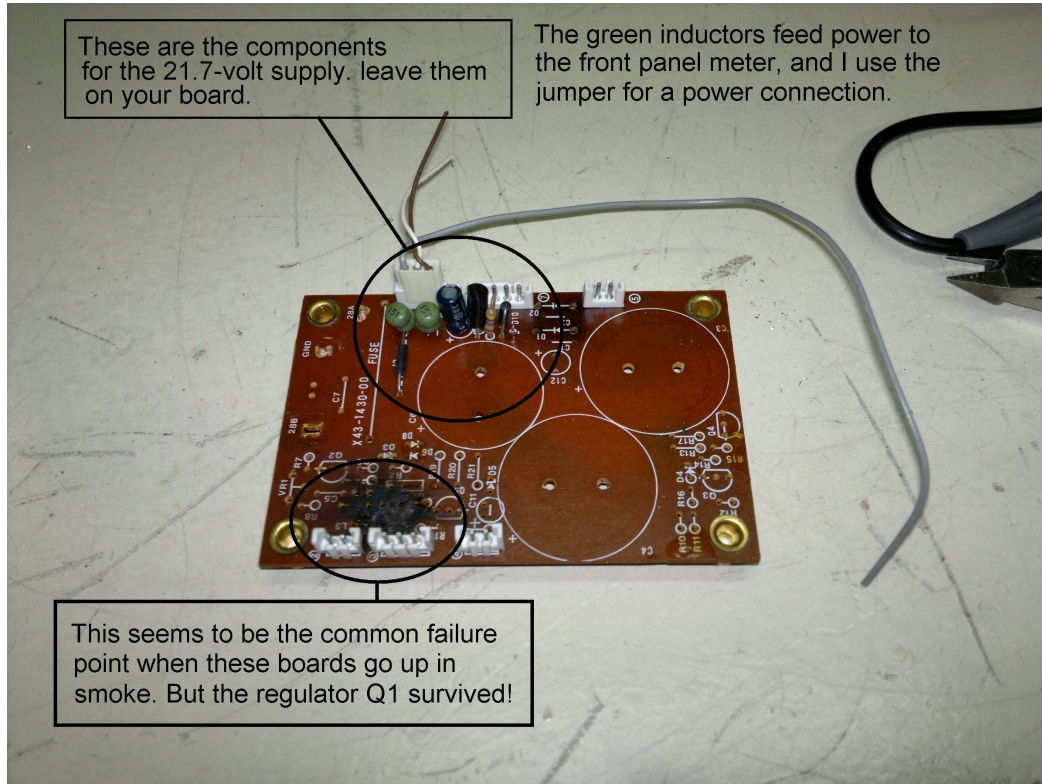

The three empty spaces for the electrolytic capacitors and their associated foil traces are perfect for distributing power to the remaining circuits, as shown below. **NOTE:** THE RED WIRE in the picture below is not necessary if you left the orange wire to the 21.7 volt plug intact. On this board, it had been cut so I needed to create a cross-connect.

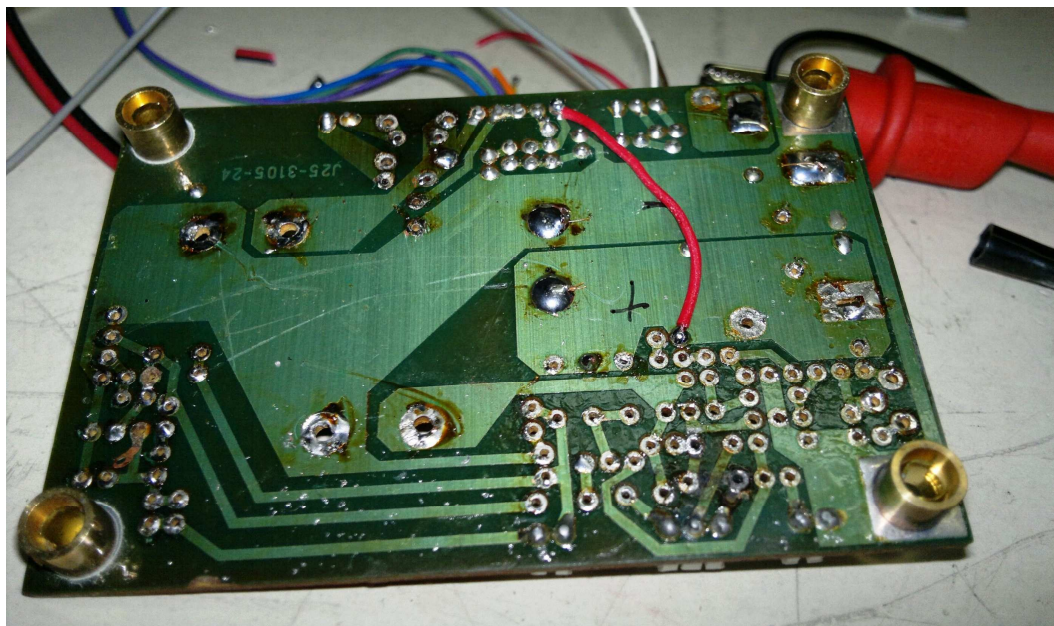

All you have to do is install 28-volt power leads to the plus and minus foils on your AVR board, and connect some jumpers to bring 28-volts to the 21.7-volt sub-regulator, and the green inductor for the Vc circuit. The other one is just mounted on the AVR board. As the schematic shows, it's a feed-through between pins 1 and 2 for the Ic circuit, so you won't be running 28-volts to it. If you use the stock fans as I did, you will need the dropping resistor unless you want them to roar at full speed all the time. I wired mine so that the PA fan blows in against the heat sink, and the PA fan blows out to draw air through the Quint and out of the rig.

Here is the later model AVR board, ready to reinstall. Remember to install the regulator transistor using an insulating mica washer or the original rubber pad, and a shoulder washer to insulate the screw. Otherwise, you will short the 28 volt B+ right to ground.

### **A late-model AVR board, ready to reinstall**

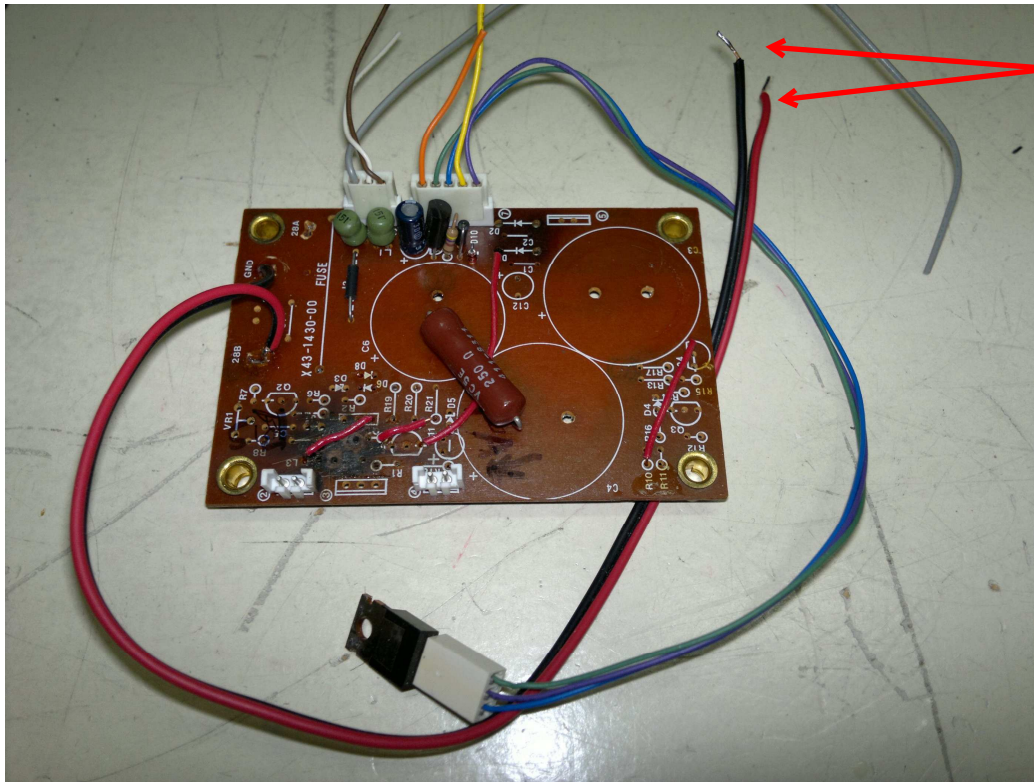

Connect these to one of the sets of terminals on the Quint.

### **ACKNOWLEDGEMENTS**

I would like to give special thanks to two HAMS who provided input while I was working on this paper. They are Gary Mankoff (N6BIZ) in California, and Mike Hutchins (ZL1MH) in New Zealand.

Gary shipped his toasted "Post 3,100,xxx" AVR board to me so that I could figure out how to modify the later 930S to work with the Quint power supply. His board is the one you see above. This should be of great value to HAMS who have the later-model 930's.

Mike has three TS-930's, all with serial numbers under 3,100,xxx. He has already modified one using the Quint 2938604 model PS that I describe on page two. He reports that his works great also. He plans to modify the second 930S using the procedure described by VK4AMZ, and leave the last rig untouched as a "control".

When I first started using my rebuilt 930S, I noticed that when driving at full power into a SWR over 2:1, the dial lights dimmed and the voltage dropped. I blamed the Quint. However, Mike tried that with his unmodified 930S, and he had similar results. It turned out to be caused by the ALC circuit. We corresponded at great length while I wrote this paper, and his input has been invaluable.

FINAL UNIT (X36-1430-00)

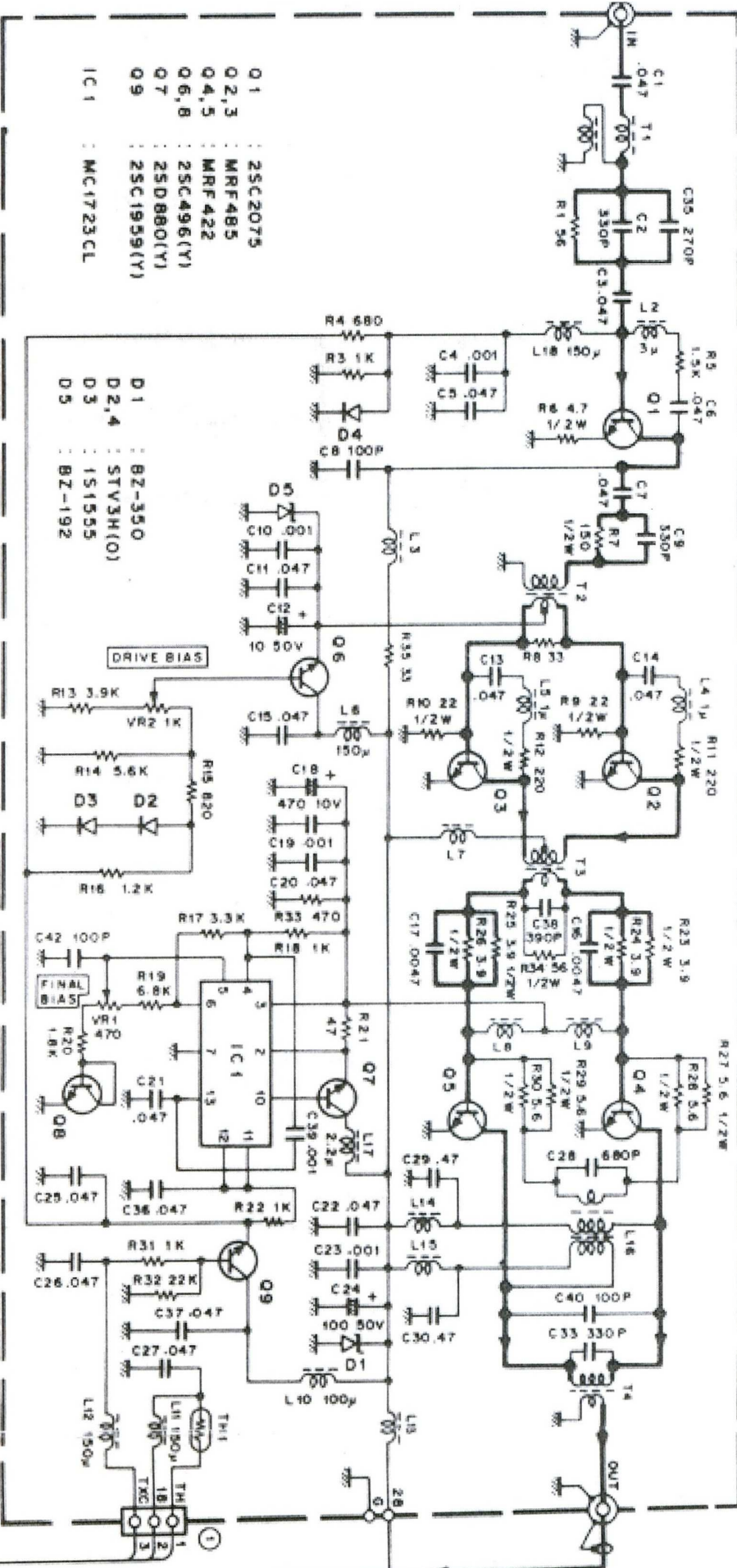

- Q 1 : 2SC2075
- Q 2,3 : MRF485
- Q 4,5 : MRF422
- Q 6,8 : 2SC496(Y)
- Q 7 : 2SD880(Y)
- Q 9 : 2SC1959(Y)
- IC 1 : MC1723CL

- D 1 : BZ-350
- D 2,4 : STV3H(O)
- D 3 : 1S1555
- D 5 : BZ-192

DRIVE BIAS

FINAL BIAS

