

# A COMPENDIUM OF INFORMATION ON REPAIRING YOUR OWN KENWOOD TS-930S TRANSCEIVER

(MUCH OF WHICH SHOULD APPLY TO THE TS-940S AS WELL)

By John P. Young, W3AFC

Rev. 7: 02/17/2017

Contributors (To date, in order of appearance)

Gary J. Mankhoff, N6BIZ  
Mike Hutchins, ZL1MH  
Dave Phillips, KB7JS  
Marcel De Vuyst, ON7DY  
Luis Velazquez, K4BTA  
Rich Carter, KE1EV  
Ken Grant, VE3FIT

Special thanks to Paul Groothoff, PA2VC, for his groundbreaking work on replacing the OEM power supply with a modern Phoenix Contact supply.

This will be a “Living Document”, meaning that it will grow as the work from new contributors is added in. For now, these are the sections that are contained herein. It is assumed that the reader is more interested in regaining the radio’s functionality, rather than restoring it to an OEM state.

## SECTION 1: The Power Supply

## SECTION 2: The Power Amplifier

## SECTION 3: The Digital Board

## APPENDIX

This section has additional photos, detailed Instructions, and papers written by some of the contributors, etc.

Additional thanks to:

Mike Hutchins, ZL1MH, for his experiment in which he tore apart the power supplies of two, working TS-930S rigs. He has three of them. He left one stock. He converted the second one to the Phoenix system described herein, and for the third, he modified the OEM supply using the method described by VK4AMZ, which uses some of the original components but adds overvoltage and over current protection, plus more durable regulators. He then tested all three rigs against one another and sent me an email with his findings. His email is in the APPENDIX.

Dave Phillips, KB7JS on his contributions on how he rebuilds TS-930S radios for his customers. Dave has mastered the procedure for installing the 20/26-amp Quint in these rigs. His detailed instructions can be found in the APPENDIX.

## SECTION 1: The Power Supply

Ninety percent of the problems with the TS-930S appear to center around the transformer-based linear power supply. Many have found ways to improve it using more modern components, but those solutions fail to address the heat and sheer physical weight that it adds to the radio. So the solutions offered here involve replacing the old with the new – a modern industrial switching power supply. **This conversion appears to have been pioneered, or at least advanced, by Paul Groothoff, PA2VC**, whose post in the QRZ TS-930S review forum is shown below:

*"I already repaired a few TS-930SAT's by replacing the one and only weakness of this design: the power supply. By overloading or prolonged use, the power supply fails, blowing up and delivers over 40 Volts to the rig instead of 28,5 Volts DC. In this case also the two Motorola driver transistors (MRF 485) in the RF power amplifier are unfortunately blown up and expensive to replace. The two Motorola final power transistors can handle this 40 Volts, so they will survive the attack. To replace the Motorola driver transistors please check your Kenwood dealer. Some series of the MRF 485 transistors do have a too high gain (hFE).*

*I used a high quality Phoenix Contact, industrial switching power supply, type QUINT, 24 VDC - 28,5 VDC adjustable, delivers output current 10 Amps and 15 Amps boost. Code manufacturer: 2938604, EAN code: 4017918890537 and is available worldwide. In the Netherlands available at Phoenix Contact B.V. and Technische Unie Netherlands. This power unit fits exactly on the place of the present power transformer, after removing the unnecessary parts in the new situation.*

*So here is an opportunity to repair or improve your Kenwood TS-930SAT by replacing the power supply.*

*Conversion of the power supply TS-930SAT in short steps.*

- 1. Disconnect and removal from top side: power transformer with primary and secondary wiring, regulator circuit board X43-1430-00 (desolder on this circuit board L1 and L2 to use in new situation), case with large capacitors' s, power transistors on heat sink, resistor (supply to RF power amplifier) on heat sink (to use in new situation) and temperature sensor (resistor) on heat sink (no use in new situation).*
- 2. Disconnect and removal from bottom side: circuit board with miniature relay with primary wiring from the euro plug 230 Volts AC to the voltage selector switch and wiring to the power switch of the set.*
- 3. Installation of the Phoenix switched power module: this power module is suitable for DIN rail mounting, but I removed this DIN rail clip. Mount the power supply to the original Kenwood heat sink by drilling holes in the heat sink, primary wiring from the euro plug 230 Volts AC by applying the present fuse holder and the power switch to enter the set.*

*The voltage selector switch is not used in the new situation (AC input between 85 Volts and 264 Volts), but remain it for the external shielding. Desolder the red and orange wire (28 Volts DC) from the main power switch in the front of the Kenwood, connect them together by soldering the two wires and isolate them, it 's not necessary to switch the secondary 28.5 Volts DC. Connect primary wires (phase and zero) to the front of the Kenwood, double-pole main switch and to the new power module.*

*The red and yellow wires in the area of the power supply are +28.5 Volts DC, this red and yellow wire both I have separately provided with fuse holders. The red wire is +28 Volts DC to RF power amplifier (10 Amps car fuse) and the yellow wire is approximately 2 Amps (glass fuse) to the electronic circuit boards. Check the connections and wiring of the coils L1 and L2 and write it down on paper, because it is important to connect the proper wire to the proper coil. Coil L1 and L2 are not the same value!*

- 4. Remove coils L1 and L2 from the regulator circuit board X43-1430-00 of the power supply, they are used for measuring voltage and current measurement on the meter in the set, the wires are white and brown (coils L1 and L2). Coils L1 and L2 can be directly connected and soldered to the resistor (+28 Volts DC to RF power amplifier), which previously was mounted on the heat sink.  
This resistor can be placed on the base between the digital unit and automatic antenna tuner, also can be placed on the side of the automatic antenna tuner case. Isolate all connections to this resistor and coils.*

*After performing the work, please check all connections to the power supply, the wiring to the RF power amplifier, resistor, coils and electronic circuit boards. I have the power supply adjusted at 28.0 Volt (but it is adjustable to 28,5 Volts) and the output RF power is about 120 Watts. I did not connect the fan on the heat sink, the new power supply stays pretty cool, because it has a very high efficiency.*

If you need to replace the Motorola driver transistors MRF 485, be sure you got a low hFE gain. If a green, blue or other high rank hFE is used the MRF 485 may become faulty after one hour of continuous transmission. Check the bias current after replace. Transmit for about one hour without modulating SSB or heat the heat sink with a hairdryer and ensure that the bias current does not exceed 300 mA. If the bias current exceeds 300 mA in the original radio, change R16 from 1.2K to 2.2K. The bias should be set to 70 mA.

If you have any questions about this replacement, need schematics or the Service Manual, don't hesitate to contact me. I like to hear improvements!

I also can mail you the pictures that I have made in the new situation. This Kenwood rig is worth to repair!  
I wish you very much fun with this masterpiece!"

---

I read the above posting after I calmed down following an event in which my beloved 930S went up in smoke, almost triggering the fire alarm system in our home. It took me three or four days to get over that.

My first impulse was to look on eBay for a replacement AVR board, and I found the exact one for under \$100 with shipping. But the OEM power supply was always a major concern and I began to question the wisdom of sinking money into it. I was so concerned about heat-related issues that I bought a pair of 6-inch home theater amplifier cooling fans that started the moment I switched on the rig. Heat poured out through those fans, like it was a tube rig. I investigated three modern power supplies:

- An Acopian 28-volt, 14 amp continuous (392 Watts) "Gold Box" W28MT14 power supply,
- A 28-volt, 300-watt Nao Technologies open-frame robotics switching power supply, and
- Two Phoenix Contact Quint models with outputs that are adjustable from 24 to 28.5-volts or more.

After much research, and some tinkering, I settled on the Phoenix Quint power supply. This is a high-quality noise-free industrial supply used in factories, traffic signal cabinets, etc. As PA2VC stated, it is rated at 10 amps nominal, but it has a 15-amp boost mode, and the Quint's data sheet states that at temperatures of up to +40°C (104° F) the boost mode reserve is available *continuously*. At higher temperatures, it is available for "around" ten minutes. But boost mode would not be needed that long, even in FSK mode. The Kenwood TS-930S owner's manual warns that output power should be reduced by 50% to prevent PA damage under those conditions.

There are two Quint 10-amp models that work well in the 930S. One is the original that PA2VC used, model # 2938604. There's also a shorter version, part # 2866763. There is also a new 20/26-amp Quint that fits, although it's tight. That model number is 2866776. **NOTE:** I have tried this model and it does give a slight performance edge. (See Dave Phillips' work in the APPENDIX)

A quick eBay search turned up a couple NOS surplus units for about \$70 with shipping. The model I chose is the 2866763, shown below. This version has four sets of output terminals, all in parallel, which makes it easy to hook the existing wires in. But I only ended up using two of them, so the 2938604 model which has two sets of outputs would work just as well. Both come with a rail mount on one side, which is easy to remove.



**STEP 1: Remove the old power supply.** This is the hardest part for most people if their OEM PS still works. The entire system can be removed as one unit. Cut the wires carrying the AC voltage to the transformer primary windings at the transformer. This is what you will have, except yours should have the Automatic Voltage Regulator (AVR) board still attached, and the 10-gauge red, orange, and black wires that connect that AVR to the regulators on the heat sink.

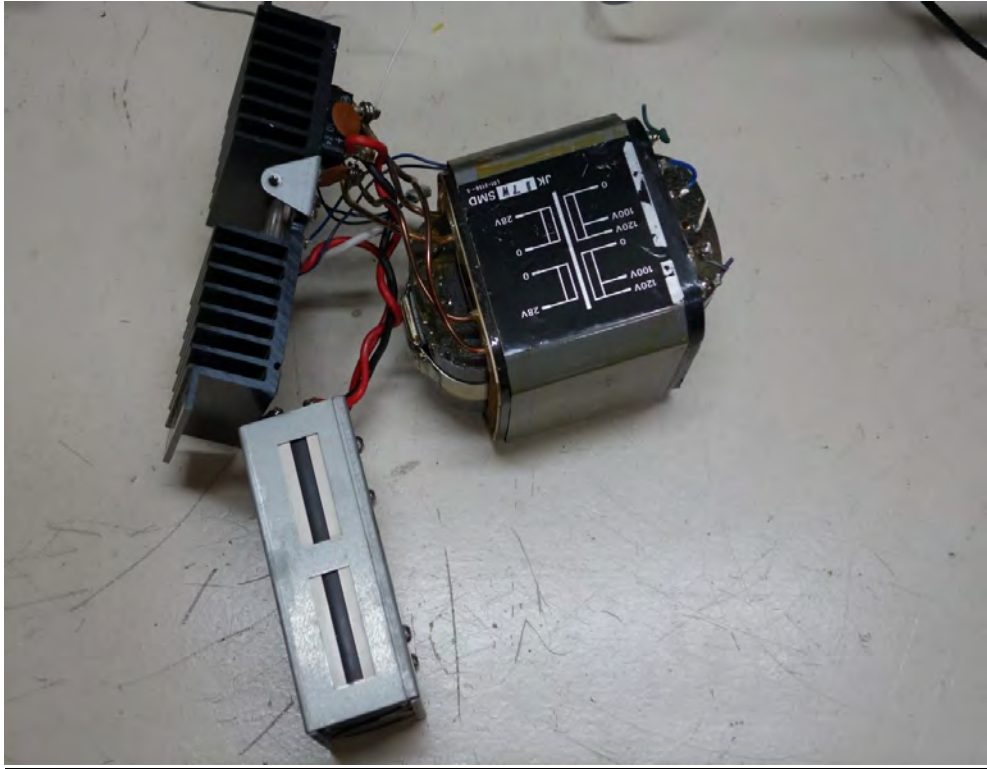

Note that the AC input switch combines individual primary windings and taps in the transformer to match the “120, 220, or 240” voltage settings. You will need to connect only two of the wires that went to the transformer to your Quint. Mine were the green and blue wires. Blue was “hot”. To be safe, use a meter to verify which two wires to use. A schematic of this circuit, from Kenwood Service Bulletin #881, is on the next page. I’ve marked the wire colors on the schematic.

PA2VC removed everything associated with the old power supply system, including the voltage selector switch and 120-Volt power relay near the voltage selector switch. Kenwood left that relay out in later models, but most have it.

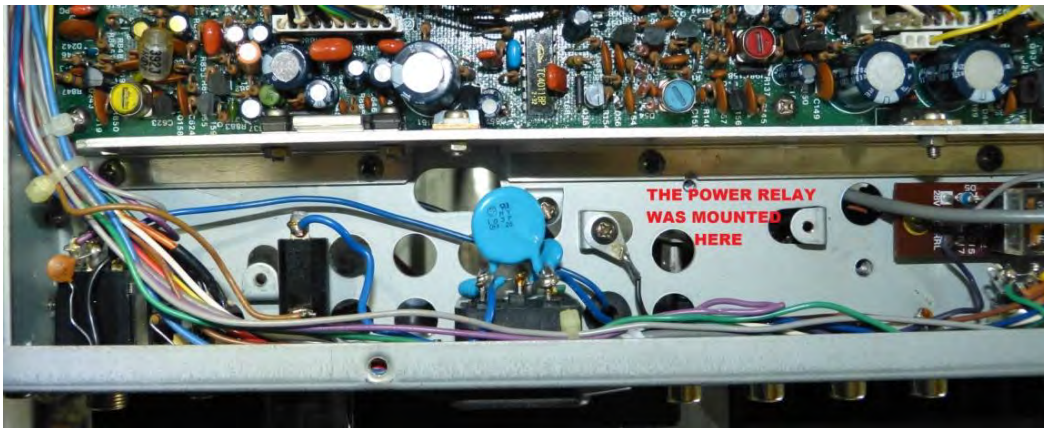

I removed mine also, but Kenwood ran very fine wires up to the front panel power switch, since they only had to carry the low current needed by the relay coil. Now they will have to provide about 3.5 amps to handle the 360 watts output. I decided to run heavier wires up to my switch, but I would leave in that relay system if it’s already there. You can just use the wires that went to the 120-volt transformer winding and remove the others, since the Quint can operate on 85-265 VAC. Contributor Dave Phillips (KB7JS) encountered a 930S that lacked that relay so he found a compatible one and installed. Sections outlining his work are in the APPENDIX.



## Kenwood's Voltage Selector Switch System – W3AFC

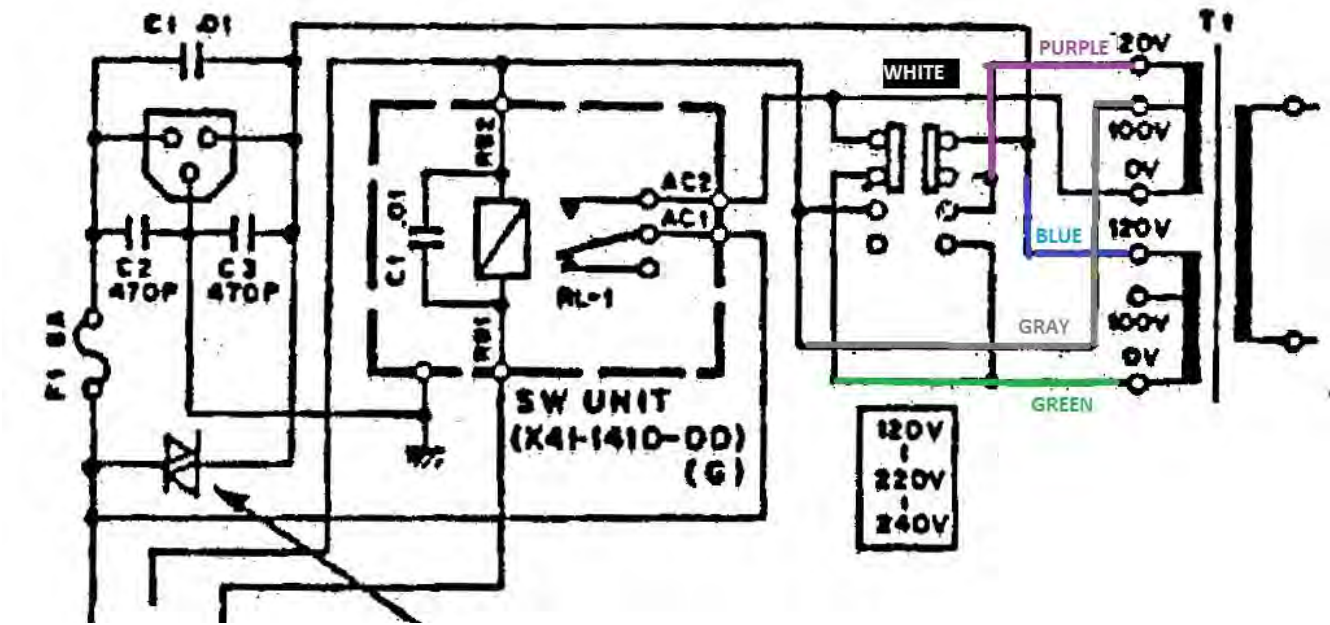

This is the only schematic of the TS-930S voltage selector switch and relay system that I have found. It is on the Kenwood USA web page as part of TS-930S Service Bulletin #881. The actual bulletin addresses surge suppression to prevent relay chatter and contact welding, but it also shows how the voltage selector switch works. Note that in the above drawing, the switch selector is set to the 120-volt position. Kenwood did not identify the colors of the wires to the transformer primary in the schematic, but based on my photos, and those of other contributors, I have added what I believe are the correct colors. If anyone finds an error, please send an email to me at [w3afc@aol.com](mailto:w3afc@aol.com).

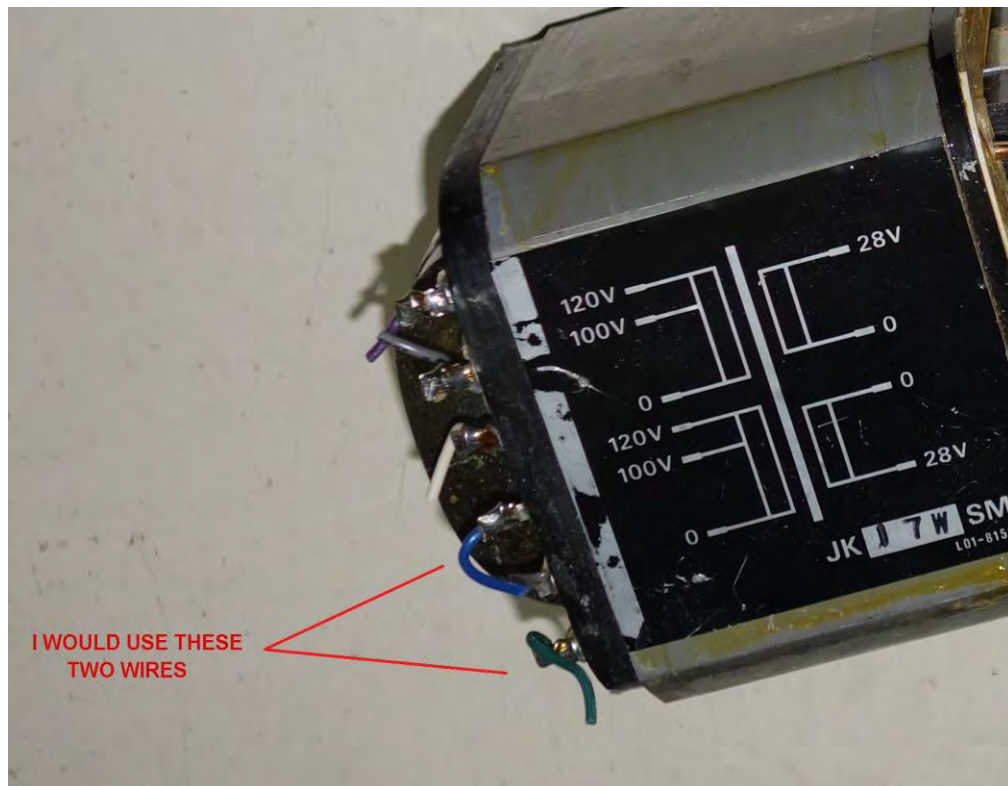

**Step 2: Decide how you will mount your Quint.** Once you have the old parts out, you can start deciding how you will orient the new Phoenix power supply, and how you will mount it. I don't recommend drilling new holes in the chassis, because stray metal shavings can cause electrical damage. This is what your space should look like now.

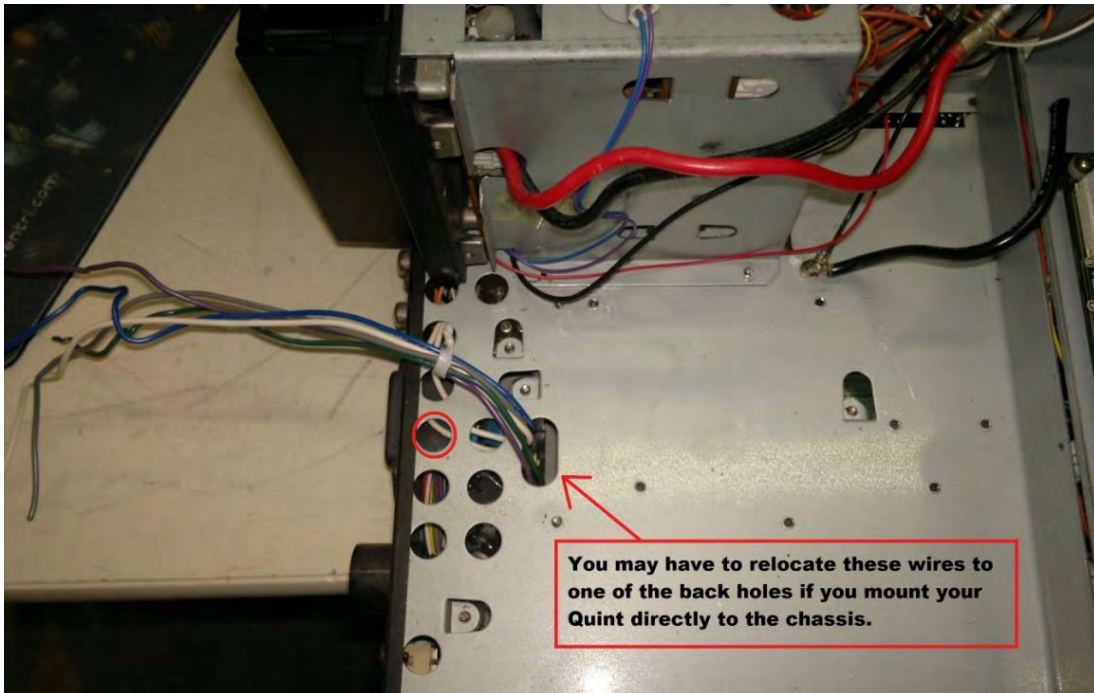

The best orientation is with the Quint vent openings in line with the fan air flow. That also places the connectors on the 10/15-amp Quint in the most convenient location. Since my 763 Quint is shorter than the 604 one PA2VC used, I discovered I could use the original transformer bracket as a mount. The width is just right. I used 3M snap lock fasteners to hold the PS in the bracket so that I could remove it to mount the components for the meter. If I take my 930S on the road, I'll put a pair of 18-inch plastic zip ties around the ends of the Quint and that bracket. But the snap fasteners are so strong and the Quint is so light that any impact that would shake it free would destroy the rest of the rig as well. You may have to shorten the top cover screw next to the Quint if it hits. Mine did.

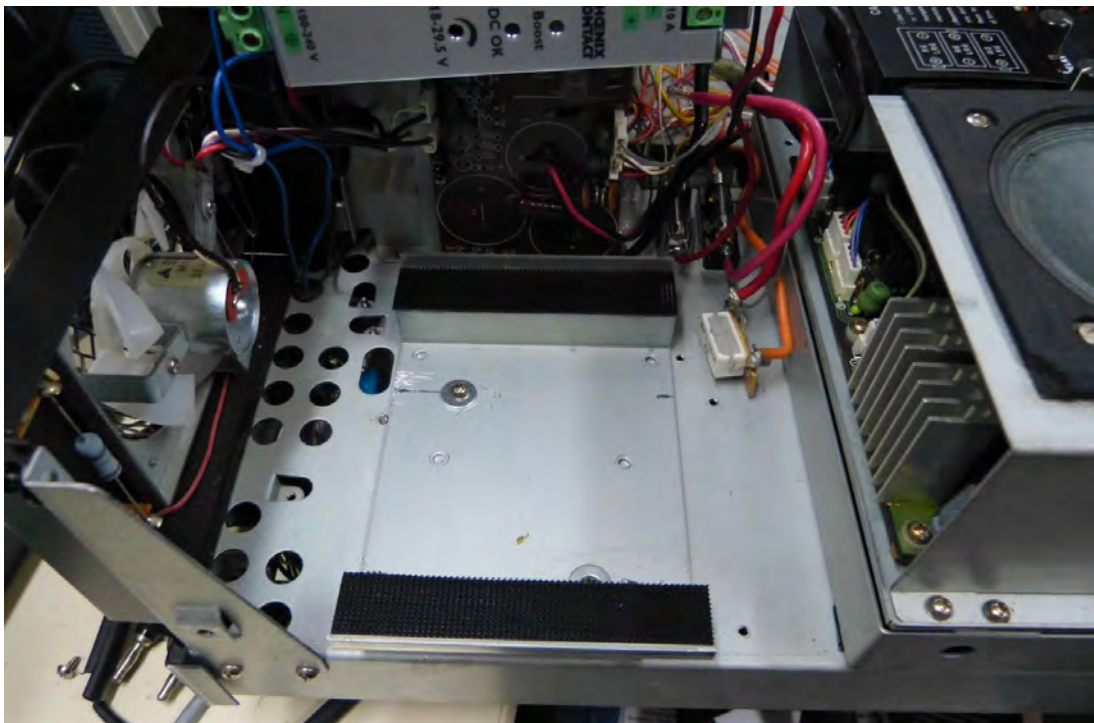



Here's a closer look at how I mounted my Quint. With the transformer bracket turned 90 degrees the air vents are in line with the heat sink fan. You can set the Quint right up against the back of the fan motor. The 0.5 ohm dropping resistor for the power out function on the panel meter isn't as close as it looks here.

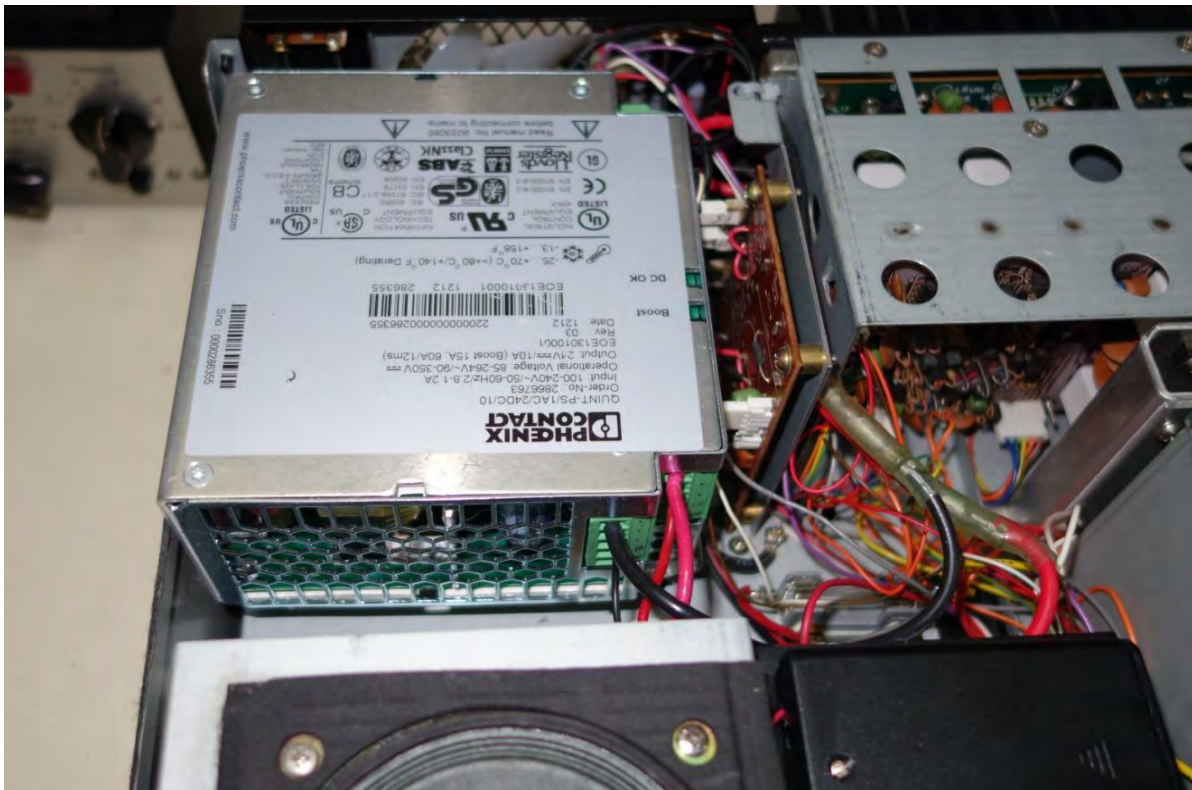
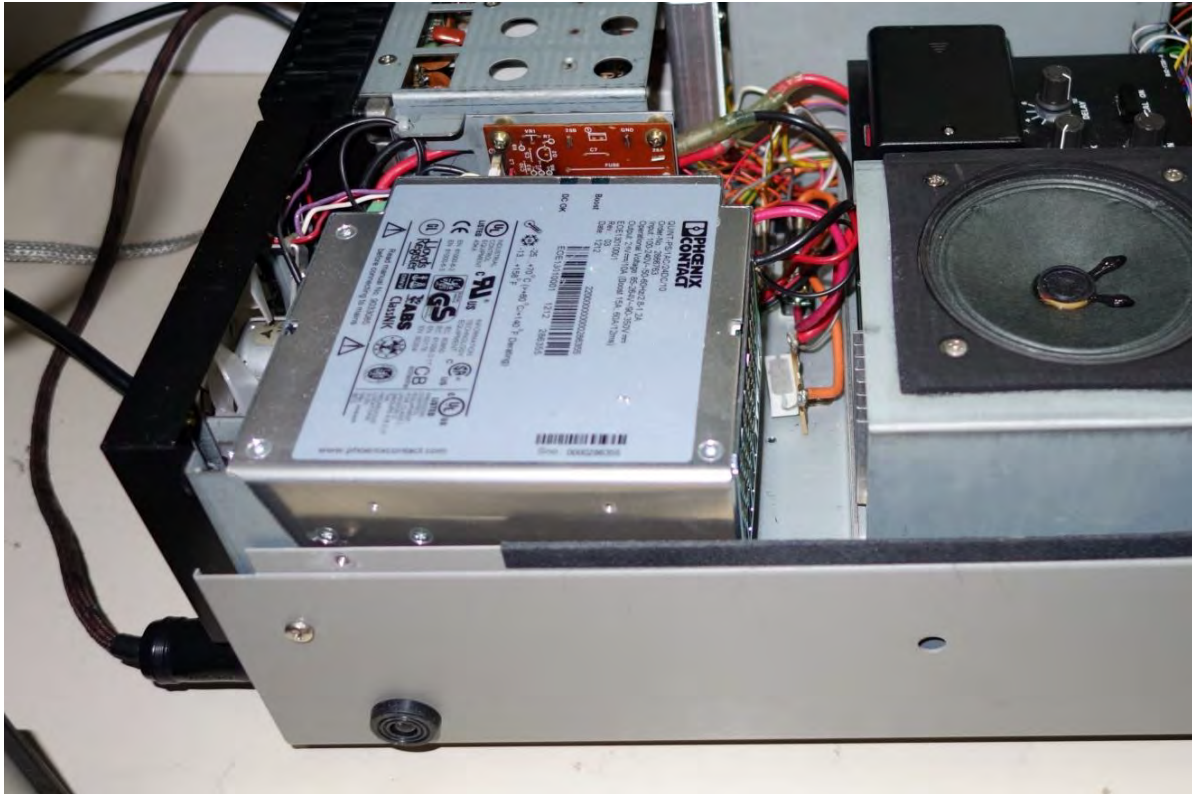

Detailed photos with notes, showing how I hooked everything up, can be found in the APPENDIX



**NOTE:** The older 2938604 model has the same foot print but it's almost an inch taller so you can't use the transformer bracket. The power supply will be too high for the top half of the case to fit. One quick yet safe option is to mount it directly to the chassis with the 3M fasteners, and then put self-stick rubber or felt pads on top so that when the top case half is screwed in place, the Quint is lightly "sandwiched" between the chassis and the top. It will never work loose.



Above photo by Marcel, ON7DY. He later removed the old heat sink to improve air flow.

HAMS can get quite creative once they plunge into a project like this. I found this photo on the web. It's turned 90 degrees to the airflow, but the workmanship looks factory issue. This could be PA2VC's radio.





**Step 3: Decide how you will mount your meter drive components.** This is where the widest variation in this process occurs. It shows how many ways there are to “skin a cat”.

Some HAMs who have performed this modification have removed the parts they need from the AVR board and mounted them on a new board or a terminal strip. I just gutted the board, leaving on the connectors for the fans, as well as the two small green inductors for  $I_c$  and  $V_c$  at the front panel meter. That also gave me a place to mount a 250-ohm dropping resistor (red) to run the cooling fans at reduced speed whenever the rig is on. I used wire jumpers to the fan connectors because the foil traces were burned off my board. The two diodes and disc capacitors circled on the board are not necessary, so you can remove them on yours. A complete section on using the AVR board is in the APPENDIX.

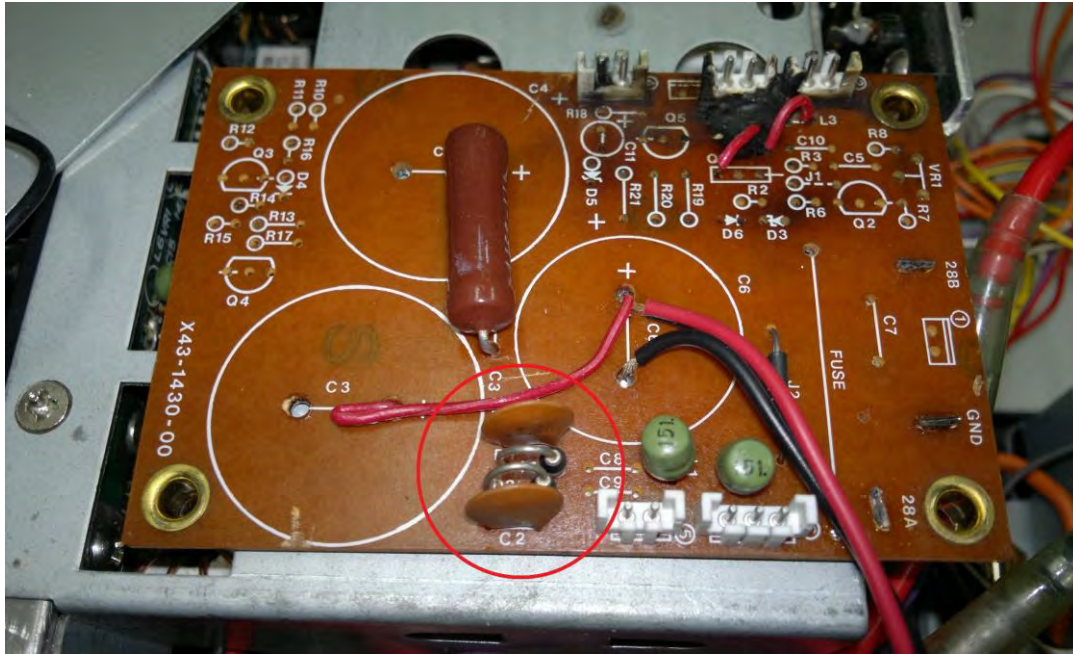

If your radio has the 21.7-volt regulator circuit on it, you can still do what I did. Details are in the APPENDIX.

Since I used my AVR board, fan connectors, and other parts, assembly was fast and easy. Those fuse holders are held down with 3M double-sided foam tape. The resistor strip is screwed into one of the capacitor bank bracket holes.

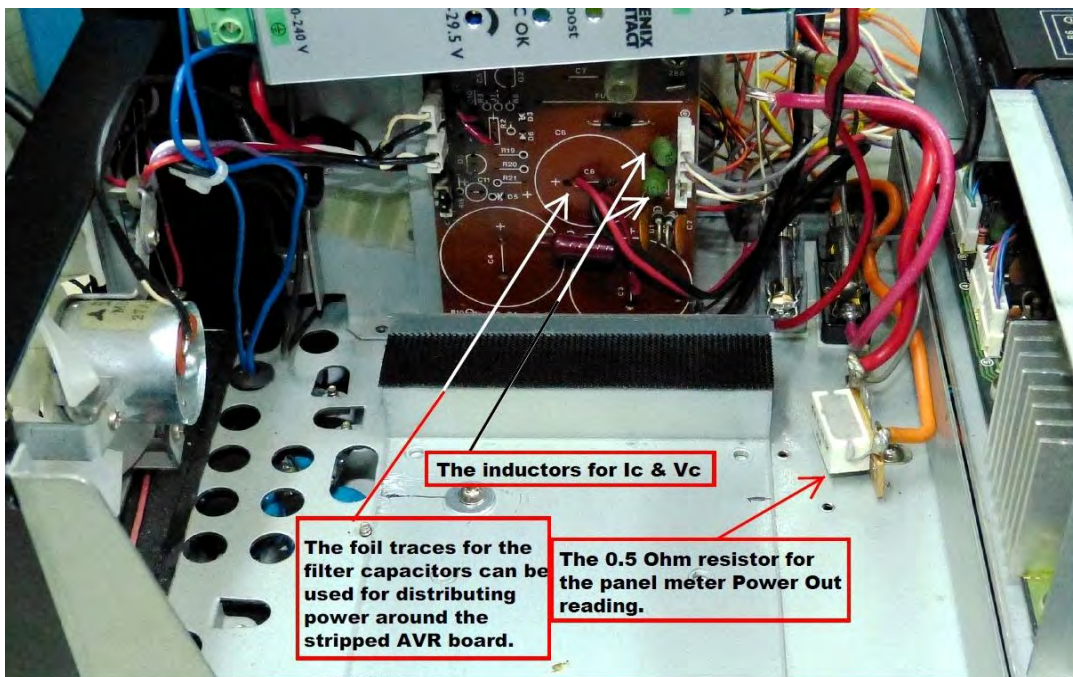

I wanted to get the receiver part back online as soon as possible, and I also wanted to make sure that the other boards in the rig were not trashed, and I was wasting my time and money. But others have gone far beyond.....



Here's how Marcel, ON7DY, mounted his fan resistor and meter drive components. He used a Velleman P1823 regulator board for the 21.7-volt sub-circuit. Since this is fed by a regulated and filtered switching PS, capacitor C4 on the P1823 board was not necessary.

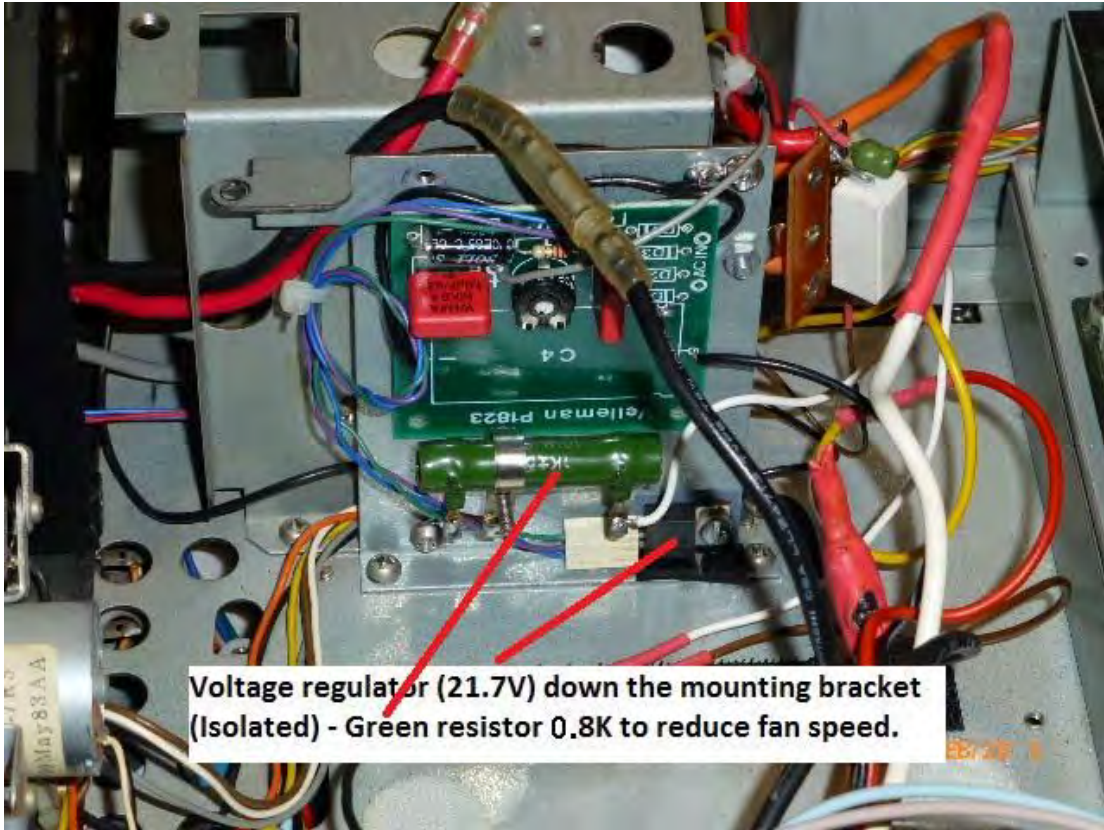

More details of how he mounted his meter drive components

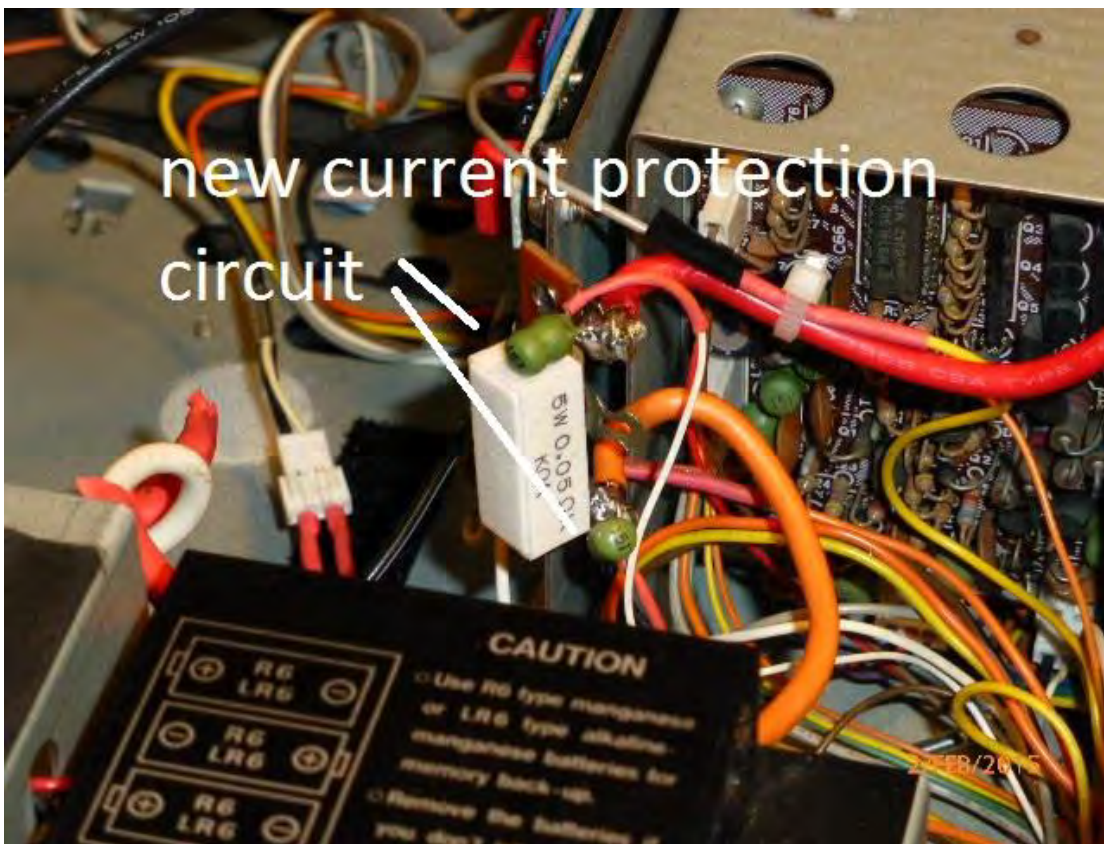

Marcel found, as I did, that it's best to toss the old PS heat sink, as it obstructs the fan's airflow. Unfortunately, that "orphans" the top left rear case screw, so I used a nut to secure the screw to retain a "stock" look.

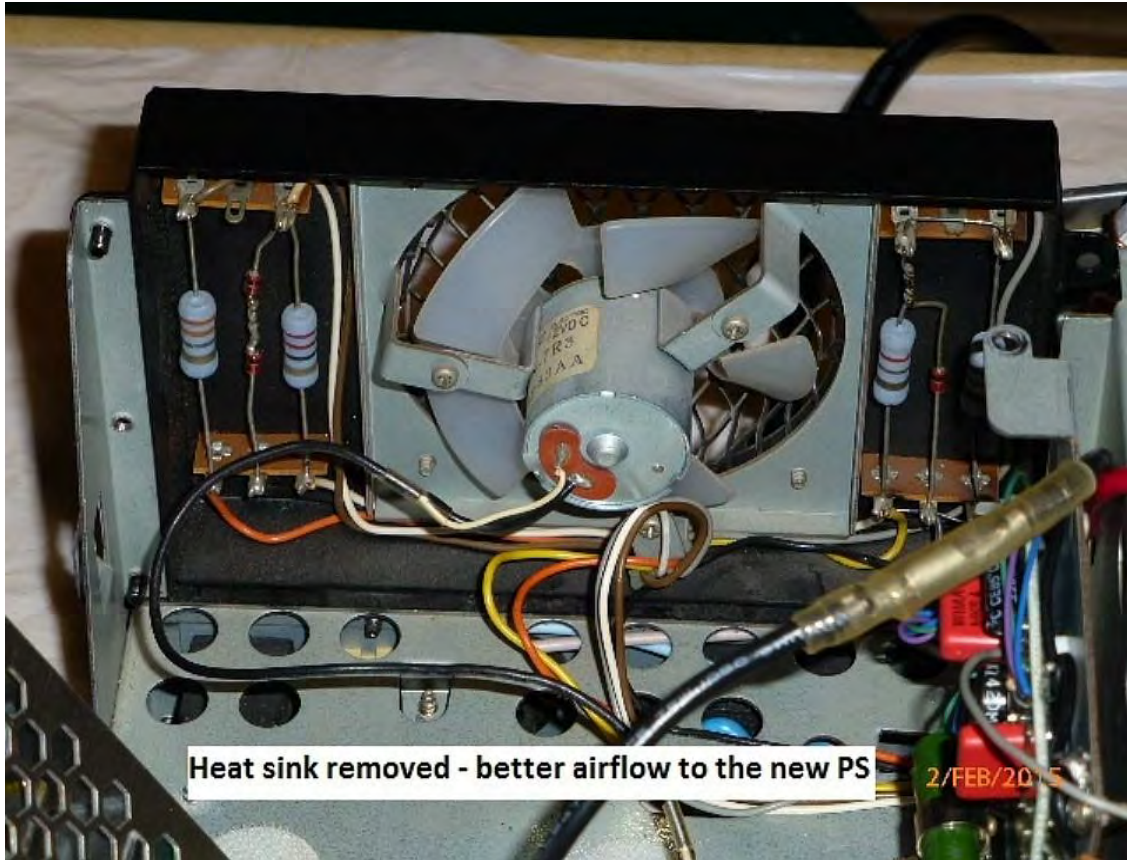

When it came to splitting out the individual voltages Gary, N6BIZ carried the sub-voltage division to new heights. He used little Chinese-made voltage regulators for all the branch circuits. A bag of five was only \$6 on eBay. He even sent a bag to me in case my resistor bank fails someday. I used one to provide 9-volts at Pin 5 of the microphone connector on my rig so that I could use a TS-940S condenser/electret hand mike.

PS. Mike Hutchins emailed me in May 2015 to say he did the same thing as Gary, and so far, everything works great. He now has TWO 930S rigs with Phoenix power supplies. And I used one of those regulators for a condenser mike drive circuit for my rig, and it is also working perfectly. So, I may convert my resistor bank soon, and add photos and info for that to this Compendium.



## SECTION 2: The Power Amplifier

If your RF output after replacing your power supply is zero, then most likely you have blown drivers in your power amplifier (PA) section. In almost all cases, the expensive outputs will still be good because their maximum Vce voltage is equal to the 40-volts that typically blows the drivers and the 19 and 36-volt Zener diodes, D1 and D5. From my experience, these are the only parts that blow when the OEM power supply fails. The drivers open, the diodes short.

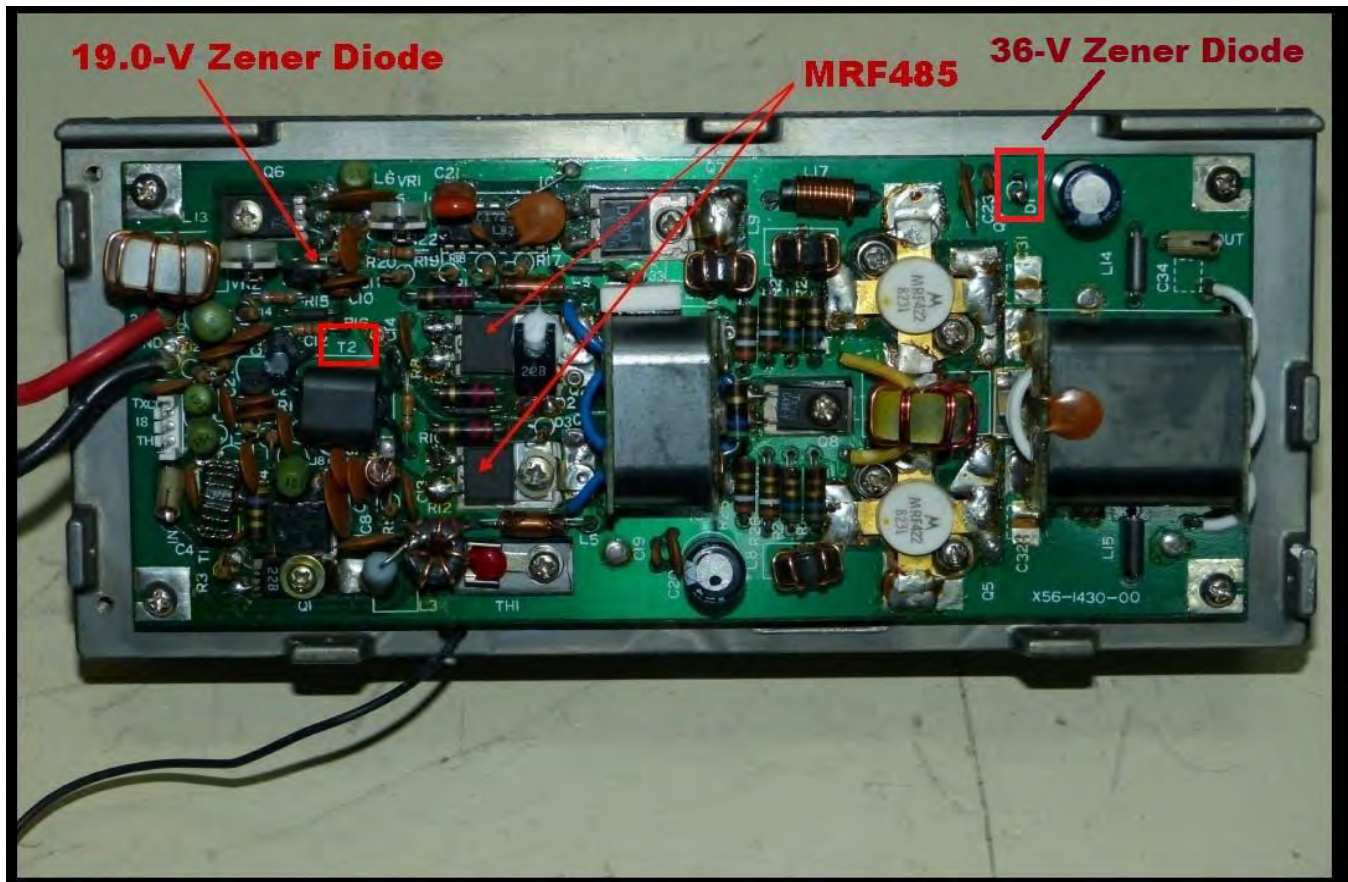

After reading about the efforts of HAMS who tried to use different drivers and had to adjust the bias, I decided to find a supplier of the OEM low-gain MRF485's <sup>1</sup>. In my opinion, this is the most practical solution. There are cheaper ones, but most have too much gain which may cause oscillations that destroy your finals. I found a seller in England who carried the Eleflow brand but he has since sold out. Click [HERE](#) for more information.

For D5, I bought a 5-watt version (NTE 3154A) for under \$3.00 to replace the original 1-watt. Zener diode D1, which clamps at voltages over 36 volts, can be cut off at the board if you use the Quint PS. For that matter, D5 is optional also. Both are intended to protect the PA from the over voltage from a blown OEM power supply, but since they are rated at only ½ to 1 watt, they fail miserably at that job.

Installation of the replacement parts is pretty straightforward. You can replace the drivers and D5 without removing the PA circuit board from the heat sink, but I removed mine <sup>2</sup>. The main thing to remember is that **the drivers must sit parallel to the bottom of the circuit board, with the top of each transistor flush with the bottom of the PC board.** Otherwise, the tabs on the drivers won't lie flat on the heat sink assembly and you may end up frying your new drivers. Study your old drivers to see how the leads were bent. You don't want to have to bend them more than once or twice because if the base or emitter lead breaks off at the driver's body, you're out of luck. Remember also not to go overboard when soldering in the drivers. The leads will be very short and the heat will go right to the transistor junctions.

Once everything is in place, it's time for some resistance and diode tests. I used the schematic from Kenwood as a guide. It comes in two sections so I stitched it together as one. A large version is [HERE](#).

1. The gain (Hfe) of my Eleflow drivers measured 10 on my inexpensive Uni-T meter.
2. I replaced the drivers in my "backup" PA without removing the board from the heat sink, and it works great.

The first thing I noticed after installing everything was that an almost dead short appeared between the emitter of the driver bias regulator Q6 and ground, and worse yet, it appeared across the Emitter-Base leads on both drivers as well. Mine measured 13.6 ohms. However, if you look at the schematic below, you will see why. Bias regulator Q6's emitter, along with D5, C10, C11, and C12 are connected to the center-tap on the secondary of RF transformer T2. And the ends of T2's secondary are connected to the bases of Q2 and Q3. Since the emitters are grounded, and T2's secondary is grounded on one end through a 22-ohm resistor, the circuit appears to be shorted - but it's not.

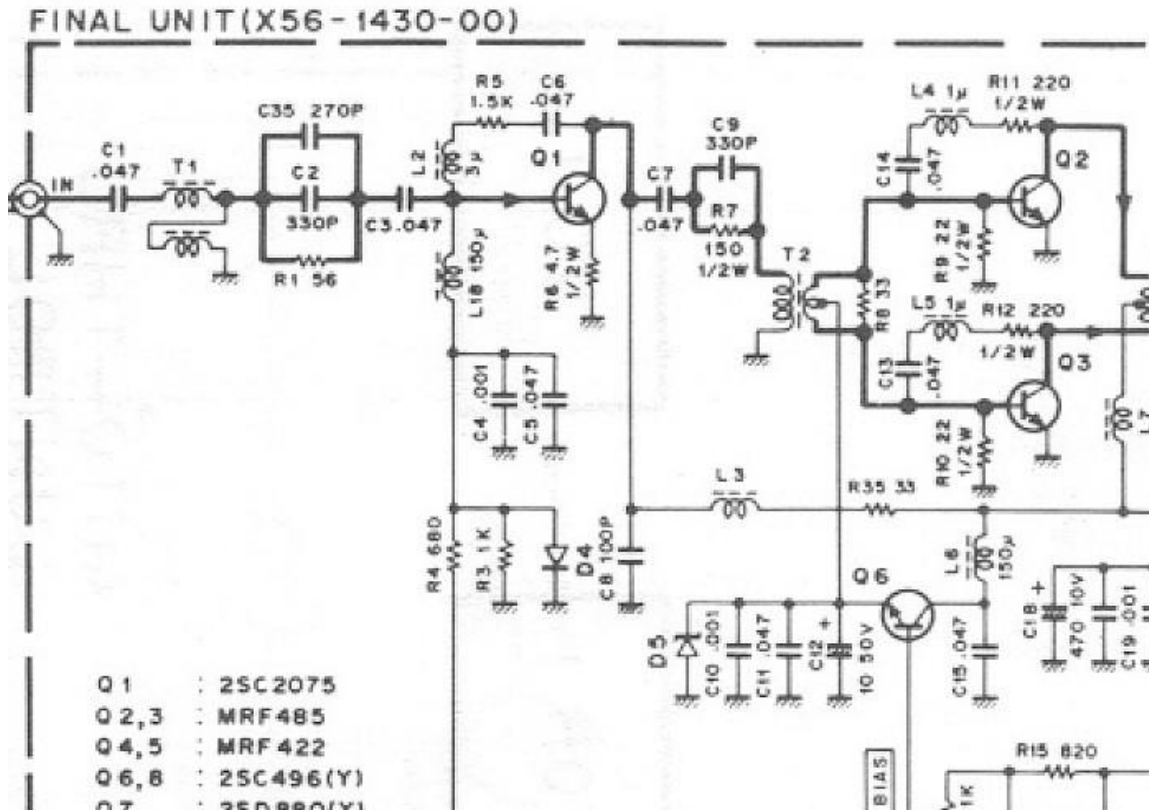

### “Pre-Flight” Tests

1. Check with a DMM to make sure all the collector tabs that should be grounded are, and those that aren't, are not. Check the shoulder washers on the collector tabs of the drivers and voltage regulators (Q6 & 7) to make sure they are insulating those components from the heat sink/ground.
2. Put the negative lead from your diode tester on each driver's collector tab. Then touch the positive lead to the emitter lead, and then to the base lead. You should “see” a diode reading of about 0.577 volts at each. Don't use the screw that pins the collector tabs to the heat sink because it's a dead short to ground. (See APPENDIX)
3. Test for a diode relationship across the main power input leads to the PA. Mine read about 0.562 volts in the forward direction and infinity in the reverse. If you see a short or a low resistance in **both** directions, find out why before you apply voltage to your newly-rebuilt PA. (Click [HERE](#) for test pictures and more info)

Once you are ready, it's time to apply voltage. The PA should be connected to the rig but sitting out with the 3-pin transceiver control and in/out cables connected as shown on the next page. In fact, it's the only way to adjust the driver's 70mA idle current. You will have to unsolder L7 and insert a set of test leads there. I would run a pair of wires from the 10-amp fuse holder to the PA leads just in case something shorts.

Once you have made those adjustments you can test the PA in TUNE mode or even on the air and check for hot spots or other signs that something is amiss. Carefully touch the driver and output transistors with the back of your forefinger. If something is more than just warm, find out why.

Since I was in a hurry to get my 930S back on the air due to a contest that was underway, I failed to take pictures of this step. So, I will defer to the excellent pictures and info submitted by Marcel, ON7DY on the next page.



Marcel, ON7DY

“After delivering 40V to the PA not only he MRF’s but most of the time the Zeners D1 and D5 are shorted, remove them but you don’t need to replace them due to the self protection function of the new Quint power supply.

John told me: since I adjusted my PA idle current = 70mA, I haven't experienced the "flickering" dial light phenomenon that he mentioned in his earlier paper.”

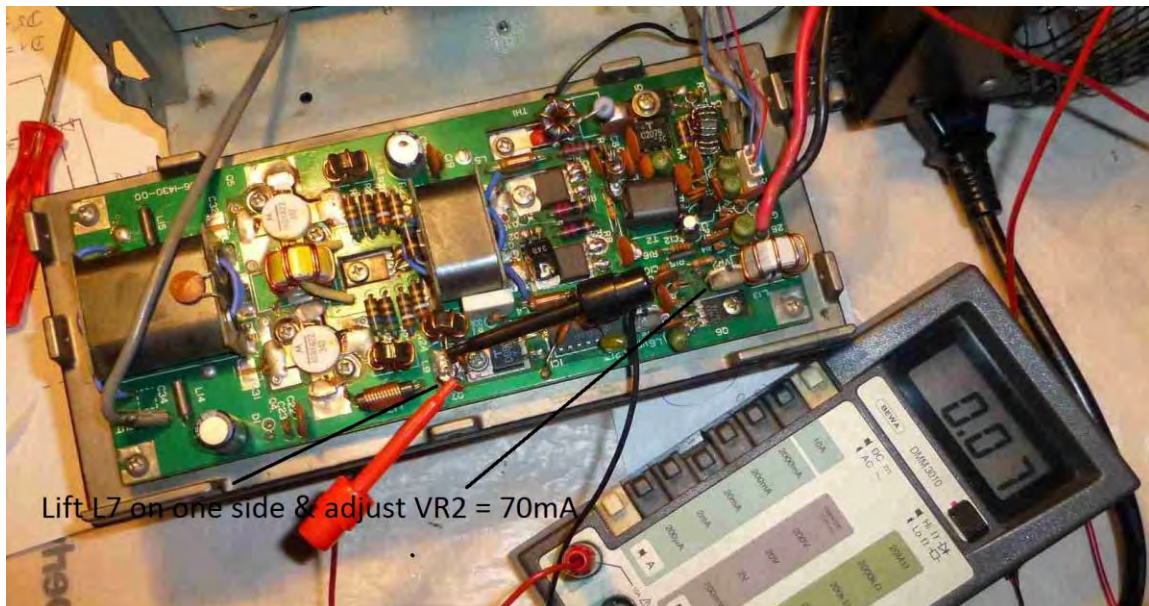

Note how Marcel lifted the side of L7 near the regulator to set the idle current. Extreme care needs to be taken here. The main idle current measurement shown below is much easier.

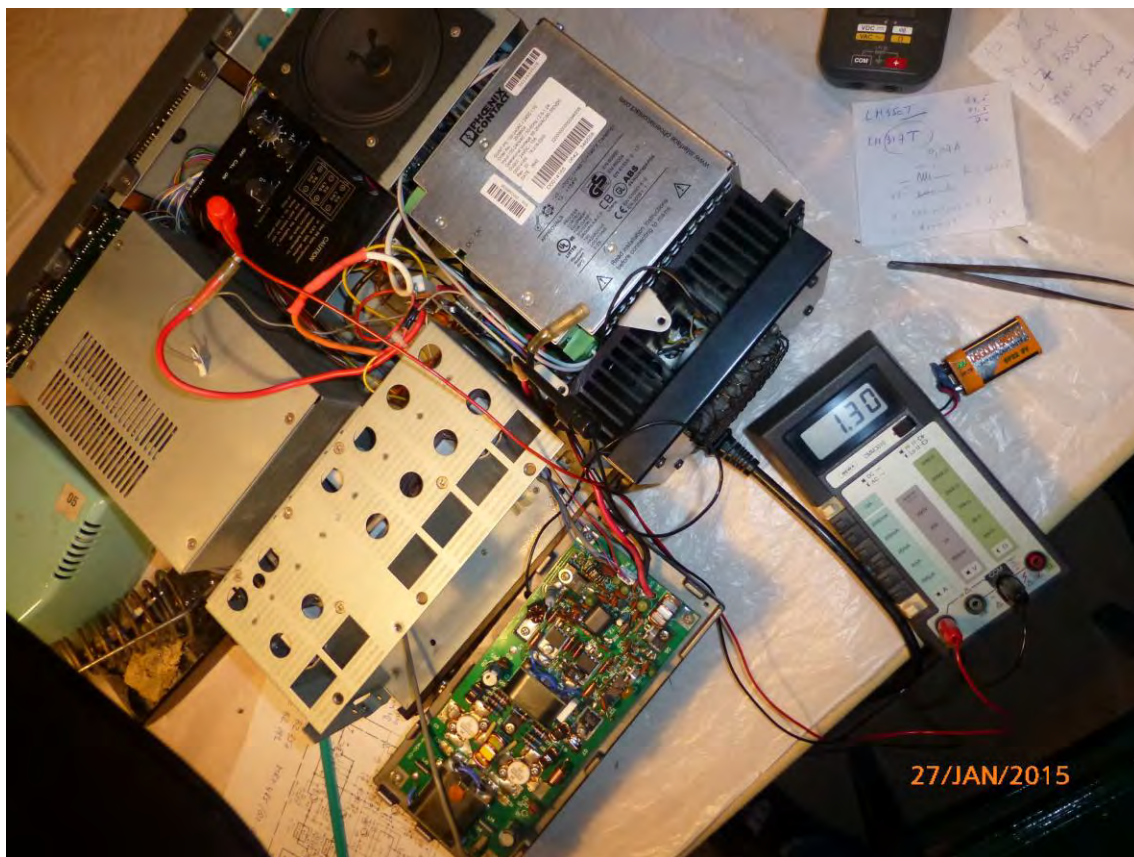



**W3AFC:** I bought a blown PA for \$55 on eBay with free shipping so I could have a backup. I rebuilt this one without pulling the board from the heat sink. I decided to test it and my main PA in TUNE and SSB mode to see how much current they used, and if the drivers or finals got hot. Here are some pictures.

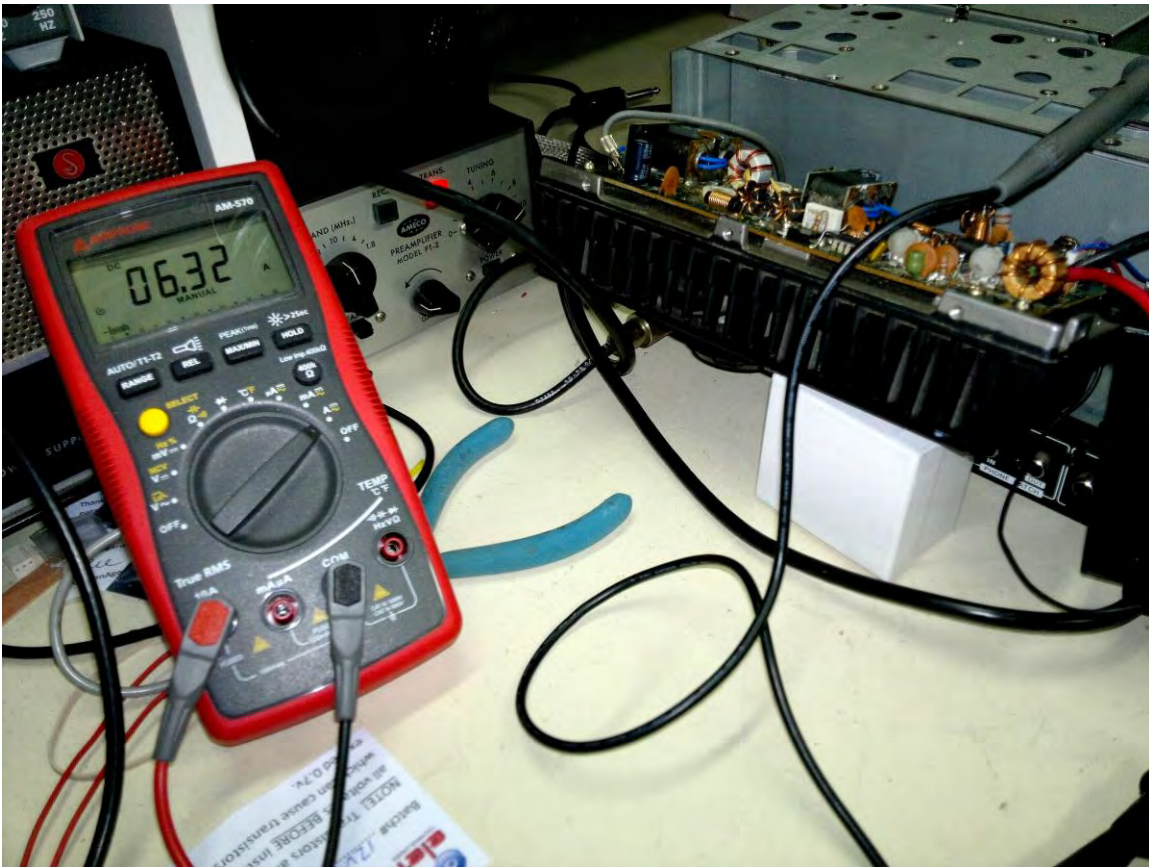
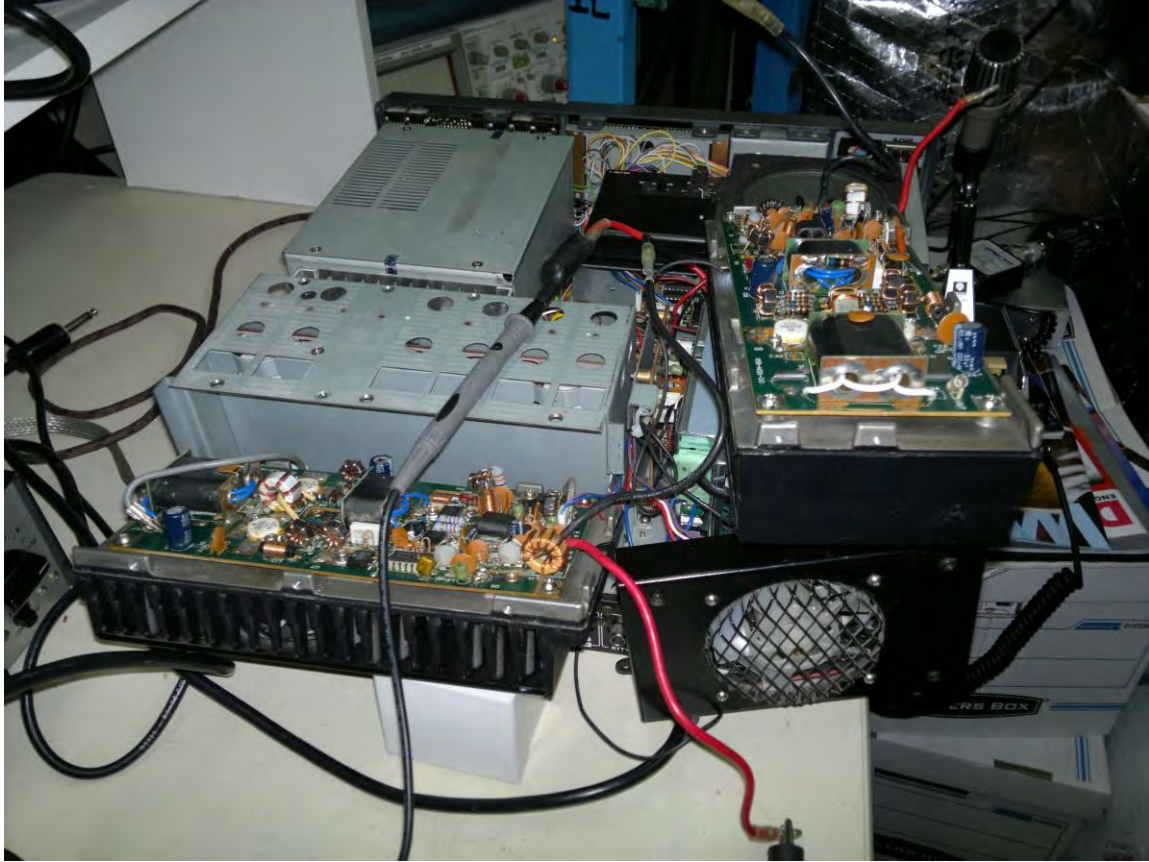

The two Power Amps performed almost identically. Both consumed around 6.3 amps to produce 52-55 watts in TUNE mode, which translates to 175 watts input power with my Quint voltage set at 27.8 volts DC.



That's only about 30% efficiency. Yet in full SSB, both amps only used 8.8 to 9 amps to produce full output of 110-120 watts, which translates to the 250 watts input PEP that Kenwood shows in the Specifications section. Of course, TUNE mode is steady state, so it's an RMS reading vs. PEP.

By the way, I left out D5 in my spare PA, but I replaced it in my main amp. It made no difference whatsoever. Since the maximum stated let-through voltage in catastrophic failure mode of the 10/15-amp Quint is only 32 volts, replacing D5 is like replacing your body's Appendix if it fails, because the most the voltage might spike to is around 19.5 volts – only 7-8 percent over the normal Q6 emitter-ground voltage of 18 volts.



### Repairing your PA with the circuit board screwed to the heat sink.

This is the fastest and easiest way to fix your PA and get your rig back on the air. Some judgment is needed here. If your board looks clean and the heat sink compound under the blown drivers isn't all dried up, then this is a good way to go. However, if your circuit board is a mess, I would remove it so that you can clean it up and check solder joints, etc. One big benefit of fixing yours without removing the board is that you don't have to worry about things like the mica insulators for the regulators and drivers falling off the heat sink, etc. Also, it's easier to bend the driver leads into position when the drivers are already mounted to the heat sink. Just bend all three leads up at a 45-degree angle and then mount the driver. The Collector (middle) lead gets cut off, and you will end up cutting  $\frac{1}{2}$  inch off the other two leads. Be quick about soldering the leads down, but one advantage to doing this with the drivers mounted is that some of the heat that reaches the transistor junction will be dissipated by the heat sink.

The most common components that fail when the PA blows are the drivers, and the 36-volt "protection" zener diode D1. Once you pitch the OEM power supply, D1 can be simply cut off the board and left off. D5 also shorts, and it is also somewhat optional. It limits the bias to the drivers to 19 volts or less. It was shorted, on both of my PA's. If your D5 is shorted, and you want to replace it, you can still add it without removing the board. The solution will just LOOK a little funny.

The photo below shows the blown PA that I bought on eBay and repaired without removing the circuit board. Note how I replaced D5. I cut the wire to the top of the diode (the cathode), soldered a new diode to the wire, and ran it over to the ground plane at the corner of the board. Be careful not to use too much heat on the old wire from the board or the solder underneath might melt, and the wire could slip down and short to the heat sink. After I verified that it had no bearing on the PA performance, I removed it.





### SECTION 3: The Digital Board

Most HAMS who encounter problems with their digital boards simply replace them with the well-known replacement made by PIEXX. But they aren't always available, and they cost \$300. So when I turned on my 930S and saw a blank display (along with an odd whine), I knew it was time to pull it and fix it. Normally, this involves downloading Kenwood Service bulletin number 0045 and following the steps outlined therein. The steps involve simply resoldering connections or plated through-holes. My problem was caused by through-holes shown in lines 5 and 9 on the following pages.

The board is conveniently located under the metal shroud that has the speaker, VOX controls, and battery compartment on it. I pulled all the connectors, removed the board, donned a magnifier, and resoldered every strange-looking solder connection, being sure to focus on the areas shown in 5 & 9 on the next page. I also sprayed a little contact cleaner on each connector when I put the board back in. It has worked perfectly ever since.

While I was in there, I decided to modify my board to allow my radio to transmit on any frequency between 1.5 and 30 MHz. I sometimes test (using a dummy load) old marine band radios and such, so this was a desirable mod. Plus, it eliminates the possibility that the FCC will open a new frequency, leaving you stuck with a rig that can't access the new band. The mod is super simple. All you need to do is solder in two jumpers: **one from pin 9 of IC-11 to pin 12 of IC-21**, and the other **from pin 9 of IC-12 to pin 12 of IC-22**. Some references mention a third jumper, but the two shown below did the trick for me. You can tack solder thin solid telephone wire (26-28 ga) or whatever you have right to the IC pins if you like, but I found convenient points on the board that connected right to the needed pins which reduces heat to the ICs (close-ups on next page)

I was working on an old RCA Cruise Phone 35 marine radio at the time, and this mod let me test and align that old radio with ease. And if you work on or align old shortwave receivers, this mod will let you use your TS-930S as an alignment tool. A dry dummy load and the coax to the load will emit enough RF to generate a usable signal in the radio under test.

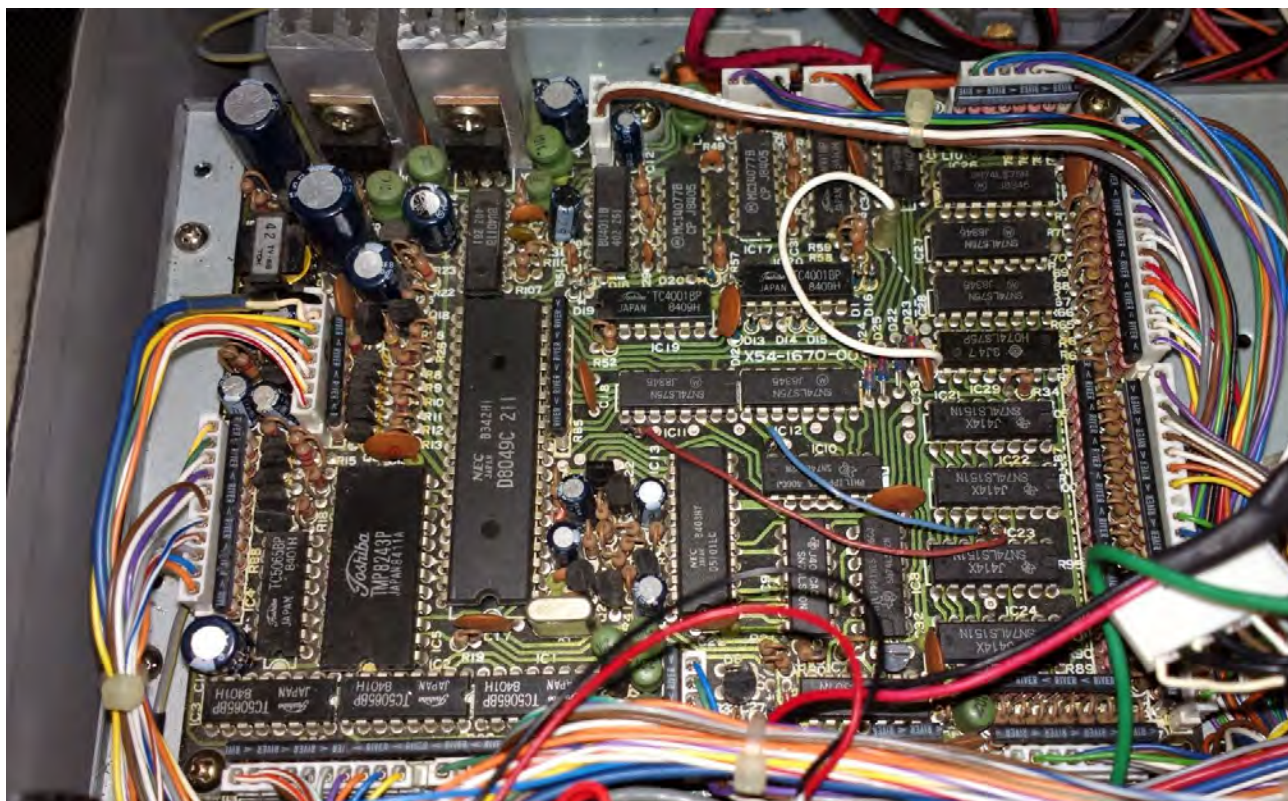

The connection to pin 12 of IC 22 is down next to IC 23. A foil trace passes under IC23 up to pin 12 of IC 22, as shown in this photo. I labeled the main pins on two of the ICs to show their numbering convention.

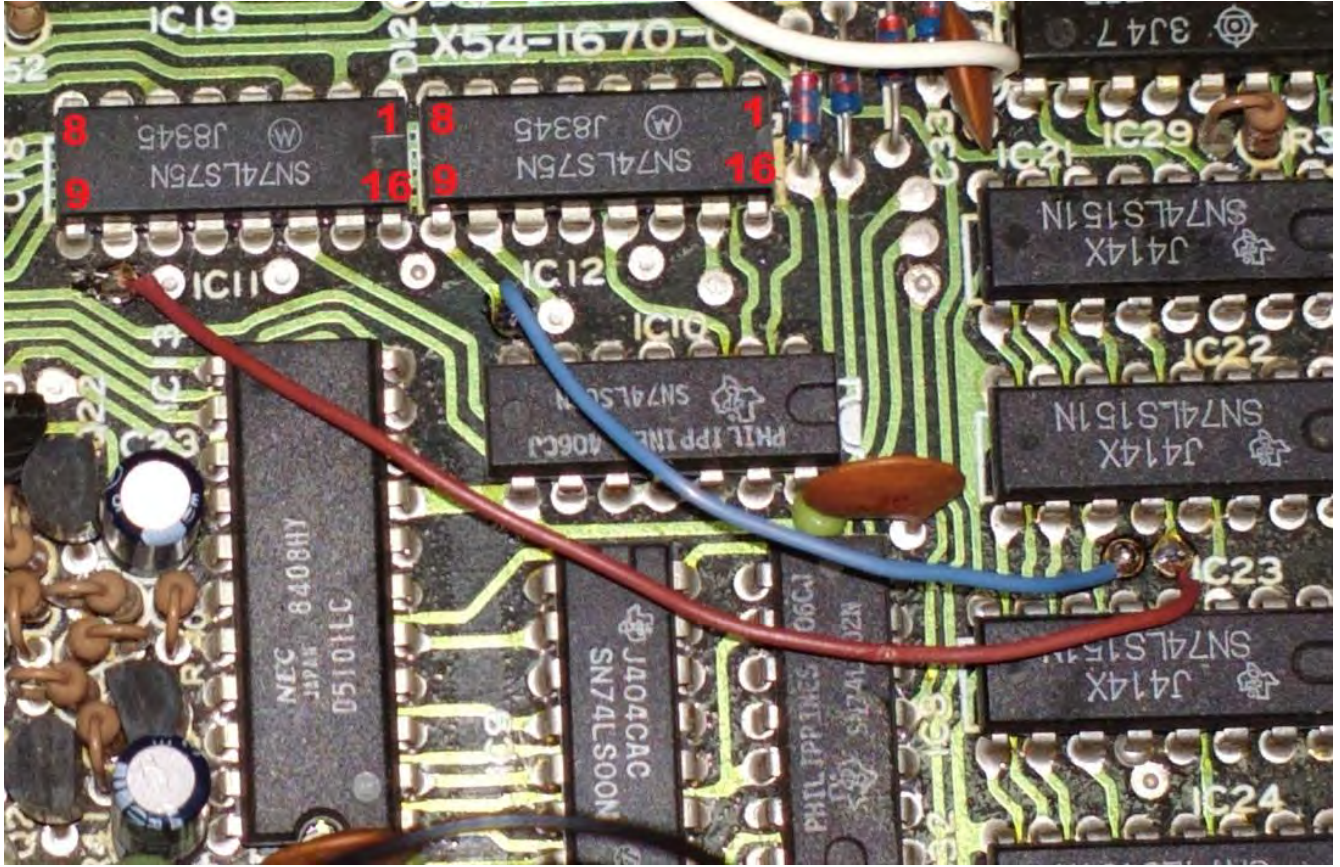



# SERVICE BULLETIN

<b>MODEL:</b> TS-930 S	<b>NO.:</b> 0045	<b>DATE:</b>																																		
<b>VON/FROM/DE:</b> TRIO-KENWOOD COMMUNICATIONS Division of TRIO KENWOOD ELECTRONICS GMBH		<b>D</b>	<b>M</b>	<b>Y</b>																																
		21	10	83																																
<b>SUBJECT:</b>  Digital Unit through-plated hole defects and their symptoms																																				
<b>CONTENTS:</b>  The unit shows symptoms as listed below, when any of the 56 Digital Unit through-plated holes are open. These examples were compiled by Mr. Negishi of the Kanto service center. Make full use of the Material as a technical reference for repair.																																				
<table><thead><tr><th>Through-hole No.</th><th>Symptom</th></tr></thead><tbody><tr><td>1</td><td>(GND)</td></tr><tr><td>2</td><td>(GND)</td></tr><tr><td>3</td><td>Transmit mode not entered.</td></tr><tr><td>4</td><td>N/C</td></tr><tr><td>5</td><td>No display. However, pressing the BAND switch operates the BAND changeover relay</td></tr><tr><td>6</td><td>Transmit mode not entered.</td></tr><tr><td>7</td><td>N/C</td></tr><tr><td>8</td><td>RIT operates in transmit mode.</td></tr><tr><td>9</td><td>Continuous tone and no display.</td></tr><tr><td>10</td><td>RIT operates in transmit mode.</td></tr><tr><td>11</td><td>(GND)</td></tr><tr><td>12</td><td>(GND)</td></tr><tr><td>13</td><td>Continuous sound. All indications are displayed.</td></tr><tr><td>14</td><td>(GND)</td></tr><tr><td>15</td><td>(GND)</td></tr></tbody></table>					Through-hole No.	Symptom	1	(GND)	2	(GND)	3	Transmit mode not entered.	4	N/C	5	No display. However, pressing the BAND switch operates the BAND changeover relay	6	Transmit mode not entered.	7	N/C	8	RIT operates in transmit mode.	9	Continuous tone and no display.	10	RIT operates in transmit mode.	11	(GND)	12	(GND)	13	Continuous sound. All indications are displayed.	14	(GND)	15	(GND)
Through-hole No.	Symptom																																			
1	(GND)																																			
2	(GND)																																			
3	Transmit mode not entered.																																			
4	N/C																																			
5	No display. However, pressing the BAND switch operates the BAND changeover relay																																			
6	Transmit mode not entered.																																			
7	N/C																																			
8	RIT operates in transmit mode.																																			
9	Continuous tone and no display.																																			
10	RIT operates in transmit mode.																																			
11	(GND)																																			
12	(GND)																																			
13	Continuous sound. All indications are displayed.																																			
14	(GND)																																			
15	(GND)																																			

# SERVICE BULLETIN

MODEL: TS-930 S		NO.: 0045		DATE:		
VON/FROM/DE: TRIO-KENWOOD COMMUNICATIONS		Division of TRIO KENWOOD ELECTRONICS GMBH		D	M	Y
				21	10	83
16 & 17	No display, display disappears when main dial is turned, or display appears when main dial is turned (when nothing is displayed).					
18	Turning the main dial generates an abnormal sound. The abnormal sound increases as the receive frequency is approached.					
19	No display. However, 80.888.8 .88 is displayed when connector (9) is removed.					
20	No display or 54.444.4 is displayed.					
21	36.222.2 or 14.444.4 is displayed.					
22	RIT-1.1 kHz is displayed when an odd numbered frequency is displayed.					
23	Only the 'g' segment of the display lights; "-"					
24						
25						
26	No display or only segments "egt" light. "1-"					
27 & 28	The main dial and UP and DOWN switches do not operate.					
29						
30	Only segments "g, DP" light.					
31	Many analog pointers light. The brightness of the pointers varies widely.					
32	All 'g' segments light. "---- "					
33	The "DP" segment remains continuously lit.					
34	Analog values from 0 to 700 are displayed, but values from 700 to 1000 are not.					
35	Segments "b,g" only are not displayed. Some of the analog pointers do not light.					
36						
37	No display because UL.					



# SERVICE BULLETIN

<b>MODEL:</b> TS-930 S	<b>NO.:</b> 0045	<b>DATE:</b>		
<b>VON/FROM/DE:</b> TRIO-KENWOOD COMMUNICATIONS Division of TRIO KENWOOD ELECTRONICS GMBH		<b>D</b>	<b>M</b>	<b>Y</b>
		21	10	83
38	No display, continuous tone.			
39	Three digits of values are not displayed			
40	ex. 14.XXX.5			
41				
42				
43				
44				
45				
46				
47				
48	(The main dial does not operate.) 14.000.0 is displayed. Turning on the RIT switch displays 14.100.00.			
49	Continuous tone. Display is locked, RIT is turned ON and 14.001.4 is continuously displayed. Transmission in no possible.			
50	Frequency varies.			
51	As if scanning were being performed. Transmission is possible.			
52				
53				
54				
55				
56				

# TS-930S PC BOARD VIEW

DIGITAL UNIT (X54-1670-00) Component side view

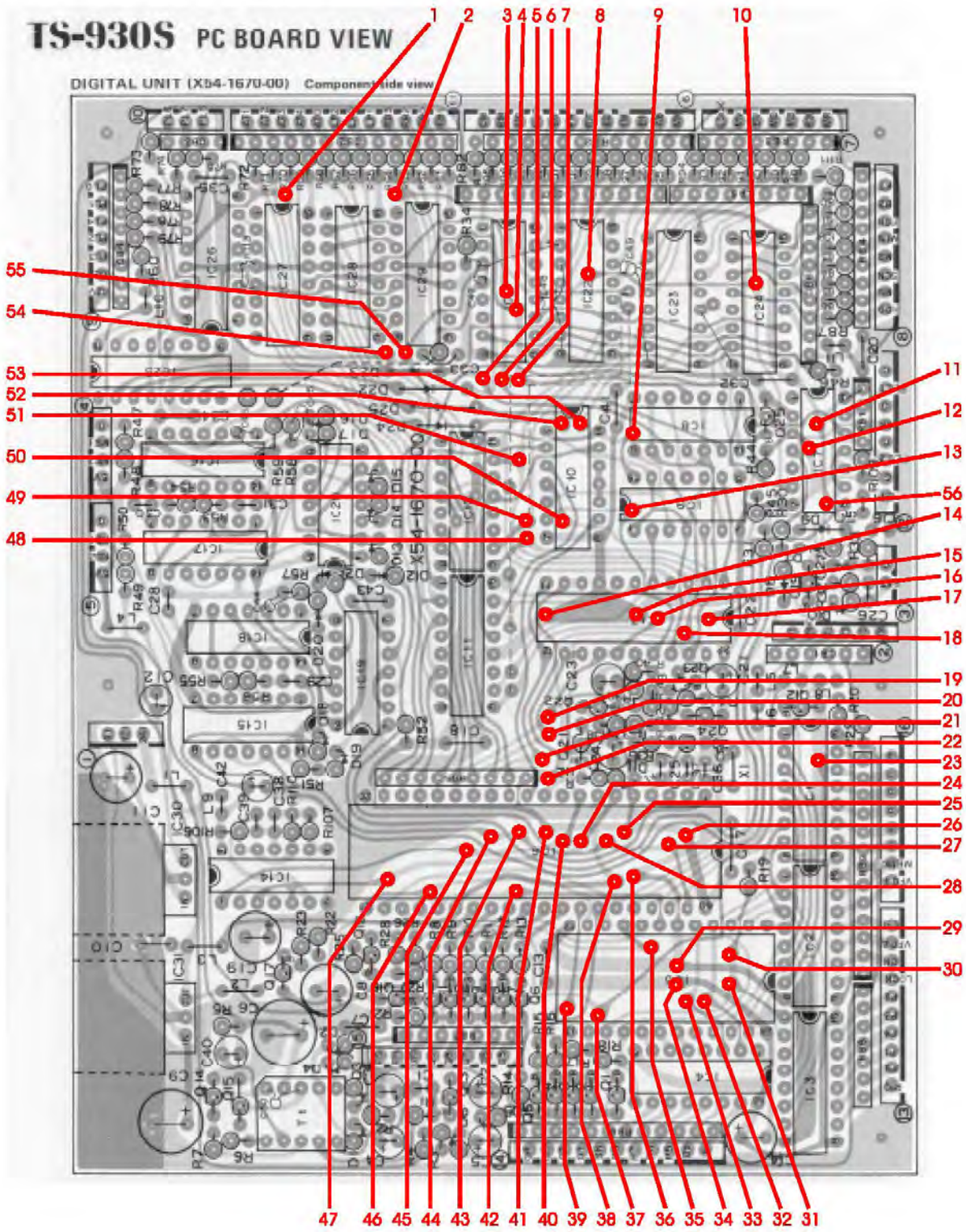



## ADDING ELECTRET (CONDENSER) MICROPHONE CAPABILITY TO YOUR TS-930S

If you've ever bought a 940S hand mic for your 930S only to find that it doesn't work, it may be because your model lacks a 9-volt, 10 mA connection to pin 5 of the microphone connector. There are lots of ways to add this. You can use a battery holder with a 9-volt battery, a resistor & zener diode on your reworked AVR board, you could connect a wire to the 8.5-volt resistor tap (gray lead) in the PS fan shroud. OR, you could install a small voltage regulator with a fuse. I wanted to try out one of the Chinese-made regulators that Gary (N6BIZ) sent to me, so I chose the last option.

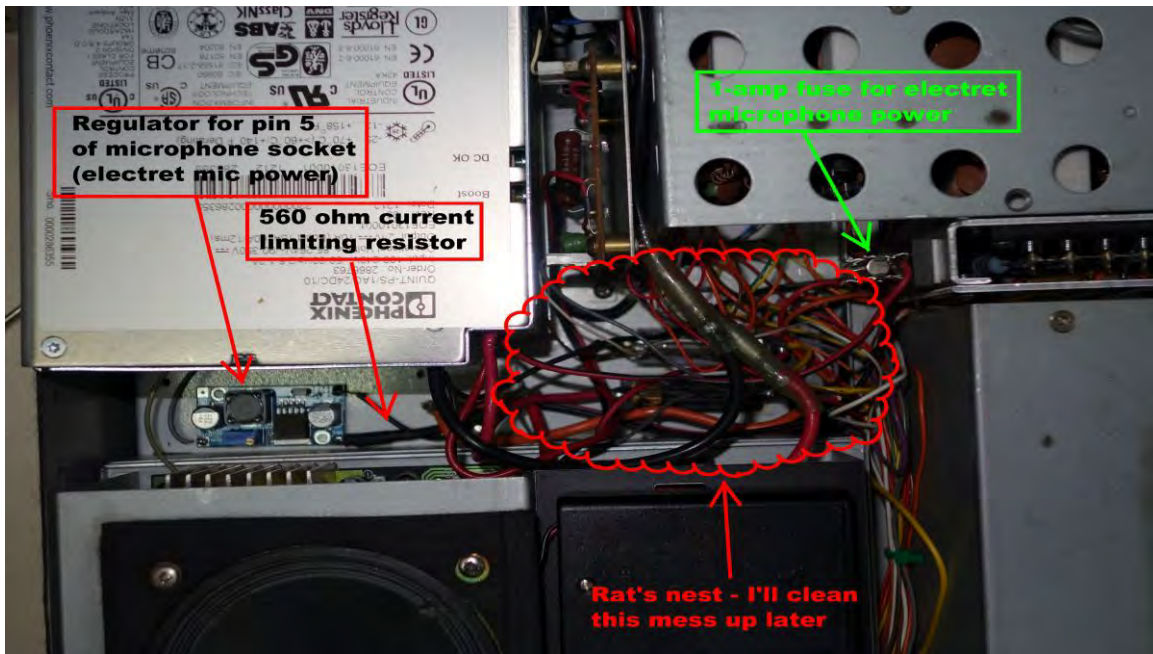

Pin 5 requires 8-9 volts at 10 mA to drive a condenser mike element, so I used a current-limiting resistor to provide 16 mA. That way, if I short pin 5 to ground, the current will be below the damage threshold. And it works well, so the 560-ohm resistor was a good choice. The microphone connector is fairly easy to reach from the bottom without tearing the rig apart. Electret microphones are MUCH more sensitive than dynamic models, so turn your mic gain way down or you and everyone on that frequency might be greeted by a loud squeal the second you hit the "transmit" button. In some cases, additional resistive attenuator circuitry may be needed to match the condenser mike to your 930S. I recommend placing that circuitry inside the mike housing rather than attenuating the input for all mikes. I'm still working on this.

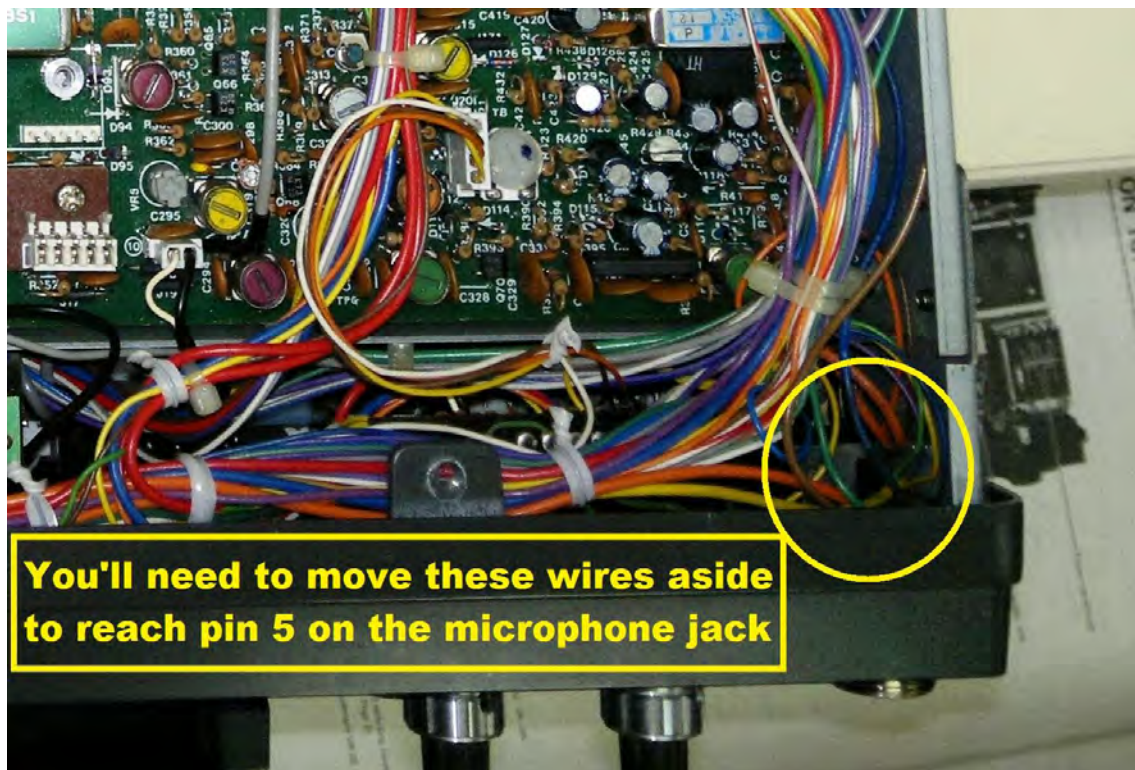

## BOOST MODE

After operating my 930S for a few days, I had to see if the Quint power supply was entering boost mode when operating at full power, so I pulled the cover and watched while I talked. I was most interested in SSB, but I also tried AM and CW modes. This is what I discovered:

On strong SSB voice peaks where the PEP reached 100W or more, the yellow boost light came on. (See photo below) On CW it came on full brightness every time I keyed down. But it stayed dark on AM, probably because AM output is limited to 30W. This suggests that the Nao Tech 28-volt, 10.7 amp power supply that I was considering in the beginning would not have had enough power to run this radio. But the Acopian 14-amp supply should have worked perfectly, had it fit.

### The Yellow BOOST Mode Light on the Quint Power Supply

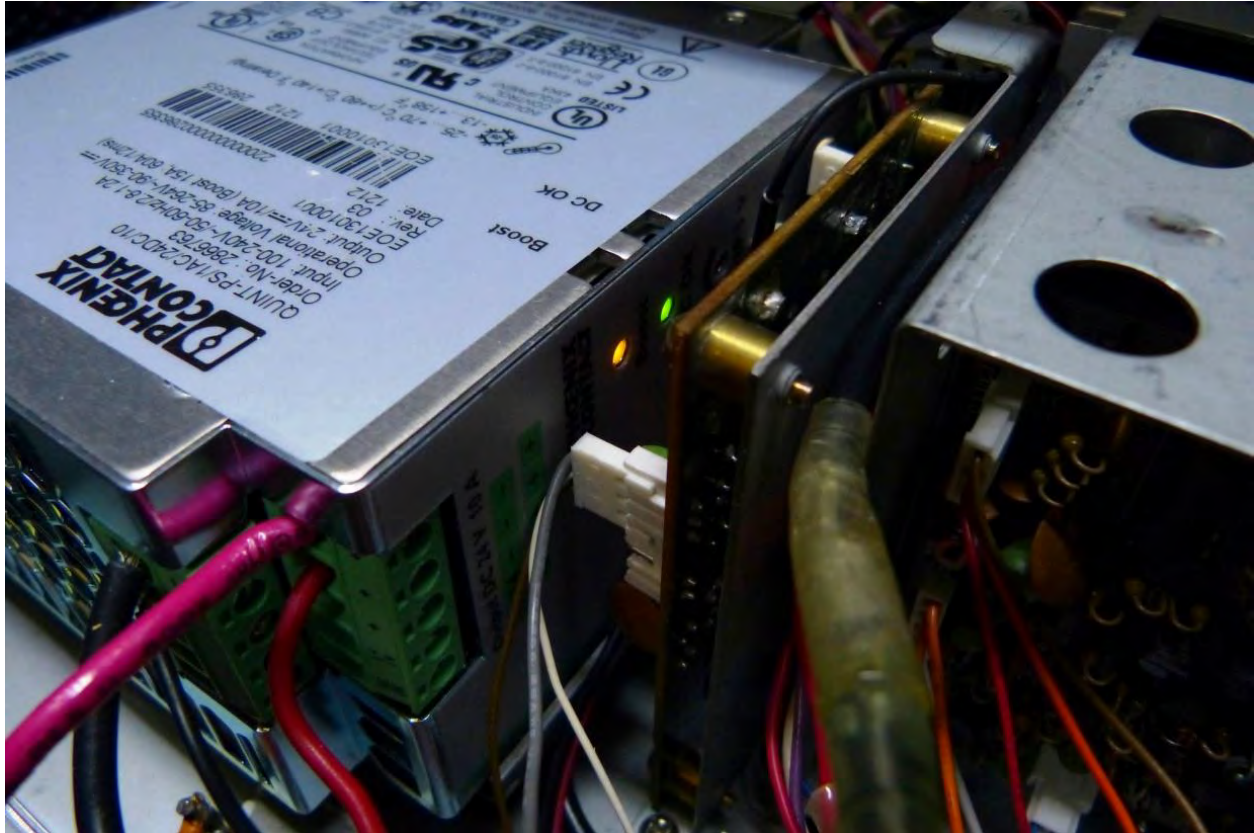



## PARTS INFORMATION

**Phoenix Quint Power Supplies: eBay.** They are on there all the time. You can find them NOS or surplus with a 14-30 day return period for \$50-\$75. Don't pay much more unless you're really in a rush.

**Eleflow MRF-485 (red dot equivalent):** I bought my Eleflows from a seller in England, but he has since sold out and has no plans to buy more. So the next best option is directly from Eleflow. They will sell to individuals but their minimum purchase is \$60.00 including shipping. They want \$14.60 each plus \$12.00 S&H, so you will end up with four drivers for \$70.40. That's really not bad, because you will have two spares. They had 200 units left in stock as of 6/18/15. Here is the contact information that was good as of the above date:

Roger Huang  
Eleflow Tech  
[www.eleflow.com](http://www.eleflow.com)  
Phone: 86-755-86329083  
Fax: 86-755-86329019  
[roger\\_huang@163.com](mailto:roger_huang@163.com)

The Eleflow brand has the lower gain (Hfe) needed to prevent uncontrolled oscillations that can destroy both the drivers and the finals. Mine measured 10 on my inexpensive Uni-T digital LCR. According to the datasheet for the original Motorola MRF-485, the gain should be between 10 and 13. I just rebuilt a spare PA for my rig with these and it produces the full 110-120 watts output, so an Hfe of 10 is more than adequate.



## TESTIMONIALS

So, how does it work? Here's what Mike, who tore two of his working 930S radios apart to modify the power supplies, had to say. He installed the Phoenix supply in one.

"Hi John - yesterday I finished my VK4AMZ power supply & put into my #3 930 & all is fine! I wired the whole power unit, heat sink & fan casing, so I can remove the 3 parts & lay them all behind the rig for checks etc., without unsoldering anything. I changed the rearmost transformer mounting clamp from a 'U' to a flat, this gave enough space to mount a 2-way connector (we call them 'chocolate blocks', guess you know what I mean!) on top of the rearmost transformer windings, with the transformer secondary into the block & flexible wires coming out to the rectifier.

To be honest, I regard the mod using the 'Quint' to be quicker & tidier, and I can't see any performance differences between the 3. Plus, like you said before, the 930 with the quint is a LOT easier to lift!!!

Hope all is well at your end!  
73 de Mike, z11mh."

### **W3AFC: One year later: How does it compare?**

Since performing this mod, this has been my everyday "go-to" rig for everything from ragchewing to all-day contesting. Even after a full day of contesting or other use, the top of the rig is barely warm. The only part that generates any heat is the resistor bank assembly in front of the Low Pass Filter assembly. If I buy another 930S, or even a 940S, I'll install a Phoenix supply immediately, even if the OEM power supply still works. So here's my testimonial – it's my baby, back in full service. I run it all weekend during contests without a glitch. It doesn't even get warm. I wouldn't use a 930S with the old power supply.





## APPENDIX

The Compendium has grown to such a large size that my web host site can't handle it as a single file. So, the sections from the individual contributors will be linked in by clicking on each name or subject below.

[Stripping and rebuilding the AVR Boards](#)

[Additional Photos and Power Supply Connections, W3AFC](#)

[“Pre-Flight” Power Amplifier Tests](#)

### HOW OTHERS REPAIRED THEIR RIGS

[Dave Phillips, KB7JS](#)

[Luis Velazquez, K4BTA](#)

[Rich Carter, KE1EV](#)

[Ken Grant, VE3FIT](#)